

TELEVISION ENGINEERING

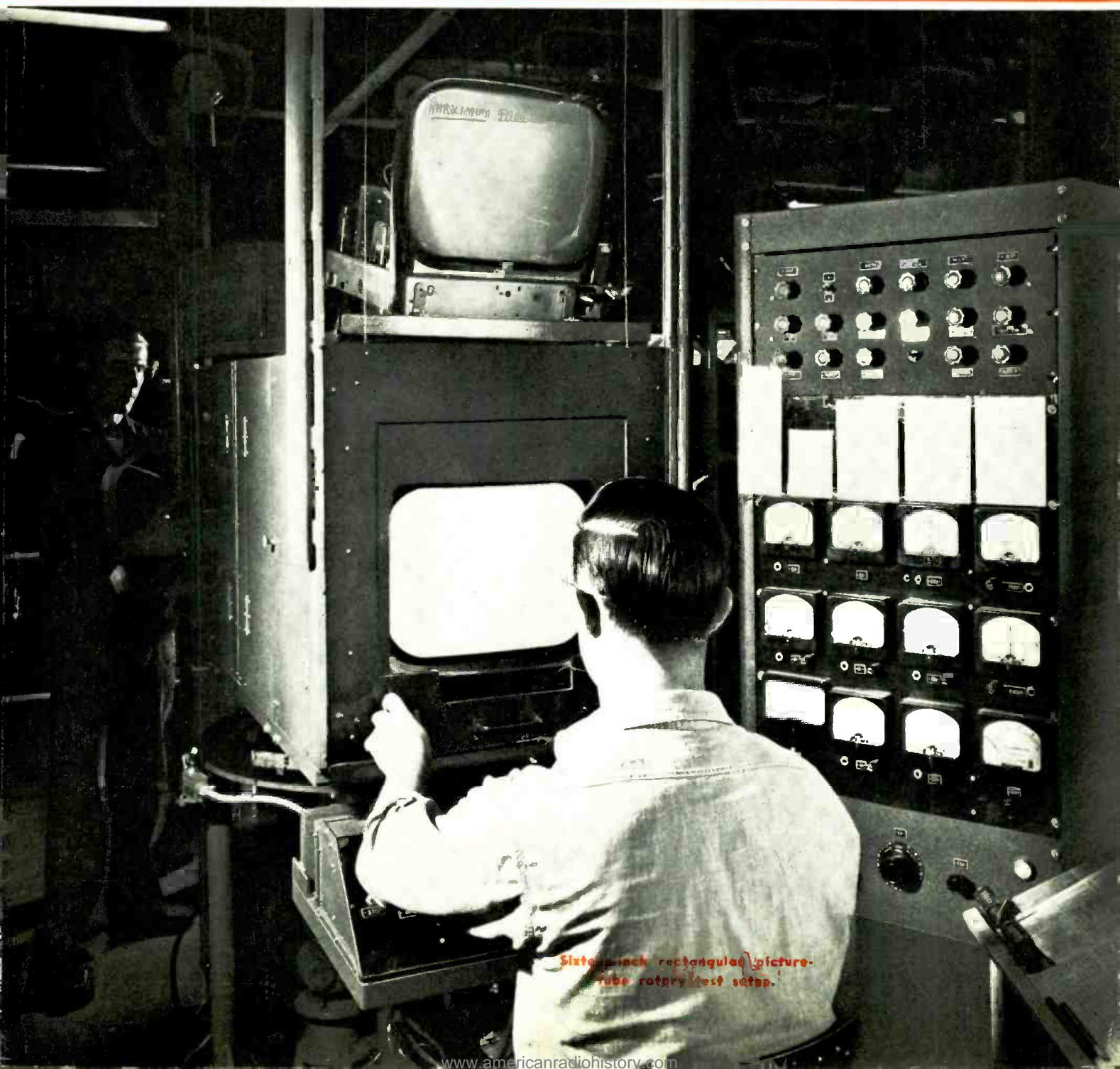

SEPTEMBER, 1950



Sixteen-inch rectangular picture-tube rotary test setup.

Proving Ground



... each year at Indianapolis,

behind the roar of racing engines, a second and often ignored drama is unfolding — the battle of the drawing board and machine shop, birthplace of countless contributions to safer, more enjoyable motoring for all.

Thomas, too, maintains its own electronic research laboratory and proving ground as an integral part of its development program. Life tests, experiments and research projects of all types carried on here are uncovering better materials, better methods, more efficient production procedures for the constant improvement of the Thomas product.

*This is your assurance of the continued superiority of
Thomas Television picture tubes — there are no finer;*

THOMAS ELECTRONICS, Inc.

118 Ninth Street

Passaic, New Jersey



ANOTHER DUMONT FIRST!

The New Du Mont-Holmes SUPERSPEED Projector

◆ Sets new standards of performance, utility and economy for TV station operation. Provides a means of film pickup that approaches the contrast and clarity characteristic of studio productions.

◆ **DIRECT FILM PROJECTOR**

Used with a Du Mont Special Image-Orthicon film pickup to give *studio clarity* to movies and teletranscriptions.

◆ **BACKGROUND PROJECTOR**

Brings dramatic moving sets and backgrounds into any studio. Eliminates costly and cumbersome sets and backdrops.

IMAGE ORTHICON PICKUP HEAD

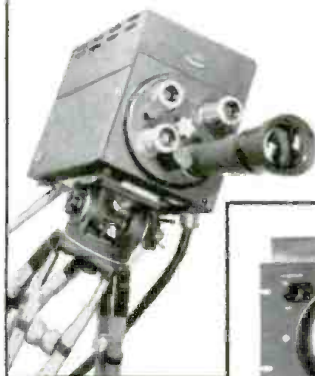

For information on the Superspeed Projector or other Du Mont Telecasting Equipment write, phone, or visit.

ALLEN B. DU MONT
LABORATORIES, INC.

FLYING SPOT SCANNER

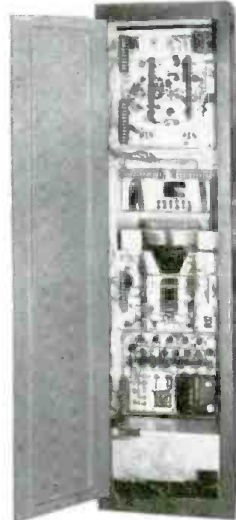

RF WAVEFORM MONITOR

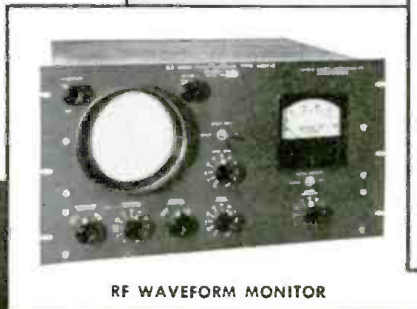

ACORN TRANSMITTER



DUMONT

First with the Finest in Television

TELEVISION ENGINEERING

Including Radio Engineering, Communications and Broadcast Engineering. Registered U. S. Patent Office.

Research . . . Design . . . Production . . . Instrumentation . . . Operation

VOLUME 1

SEPTEMBER, 1950

NUMBER 9

TVE-grams	6
<p>Reports and Reviews of Current TV News: The Color Decision and Receiver Manufacture . . . Critical Materials . . . New Color Systems . . . 30 to 3000-Microwatt Wattmeter Design . . . Ceramic Microwave Tubes . . . Theater TV . . . Silicones for Mica . . . Magnetic Wire Developments . . . New Tools for Production . . . Trends, etc.</p>	
Evaluating Video Bandwidth and Picture Quality	M. A. Honnell and M. D. Prince 10
<p>Modified Shunt-Compensated Video Interstage Analysis Reveals Degree of Bandwidth Tolerable in Receivers.</p>	
The Orthogam Amplifier	E. Dudley Goodale 12
<p>Tone Correction System Found to Provide Improvement in Overall Tone Rendition of Normal Film and Films of Picture-Tube Recordings.</p>	
Meeting the Audio Requirements in Proof-of-Performance Tests	L. B. Petery 14
<p>Practical Tests and Measuring Equipment Which Can Be Applied to Audio Circuitry to Determine Response, Distortion, etc., and Component Efficiency.</p>	
Flying-Spot Scanners	C. R. Monro 16
<p>Design and Application Features of Slide Equipment Which Parallels Service Afforded by Record Turntables.</p>	
Picture Tube Production	25
<p>Pictorial Review of Production Facilities at a Modern Picture-Tube Plant.</p>	

MONTHLY FEATURES

Viewpoints	Lewis Winner 5
TVE-grams	6
Instrument News	21
Production Aids	22
TV Parts and Accessories	22
TV Tube Developments	25
Personals	29
Veteran Wireless Operators' Association News	30
Industry Literature	31
Briefly Speaking	32
Advertising Index	32

Cover Illustration

Picture-tube rotary-test setup for 16RP4, in which one operator tests while a second operator plugs in another picture tube. A pedal serves to revolve instantly the next tube to test position.
(Courtesy Hytron Radi and Electronics Corp.)

Editor: LEWIS WINNER



Published monthly by Bryan Davis Publishing Co., Inc., 52 Vanderbilt Avenue, New York 17, N. Y. Telephone: Murray Hill 4-0170.

Bryan S. Davis, President. Paul S. Weil, Vice-Pres.-Gen. Mgr. Lewis Winner, Editorial Director. F. Walen, Secretary. A. Goebel, Circulation Manager.

Mid-West Representative: Stuart J. Osten, 333 N. Michigan Ave., Chicago 1, Illinois. Telephone: Dearborn 2-3507
 Eastern Representative: J. J. Brookman, 52 Vanderbilt Avenue, New York 17, N. Y.
 East-Central Representative: James C. Munn, 2253 Delaware Drive, Cleveland 6, Ohio. Telephone: ERieviev 1-1726.
 Pacific Coast Representative: Brand & Brand, 1052 West 6th Street, Los Angeles 14, Cal. Telephone: Michigan 1732.
 Suite 1204, Russ Building, San Francisco 4, Cal. Telephone: SUtter 1-2251.

Reentered as second-class matter February 7, 1950 at the Post Office at New York, N. Y., under the act of March 3, 1879. Subscription Price: \$3.00 per year in the United States of America and Canada; 50c per copy. \$4.00 per year in foreign countries; 60c per copy.

The Aro Book Depot: Wellington, New Zealand. McGill's Agency: Melbourne, Australia.

TELEVISION ENGINEERING is indexed in the Engineering Index.

Entire Contents Copyright 1950, Bryan Davis Publishing Co., Inc.



It takes Experience to make a Leader

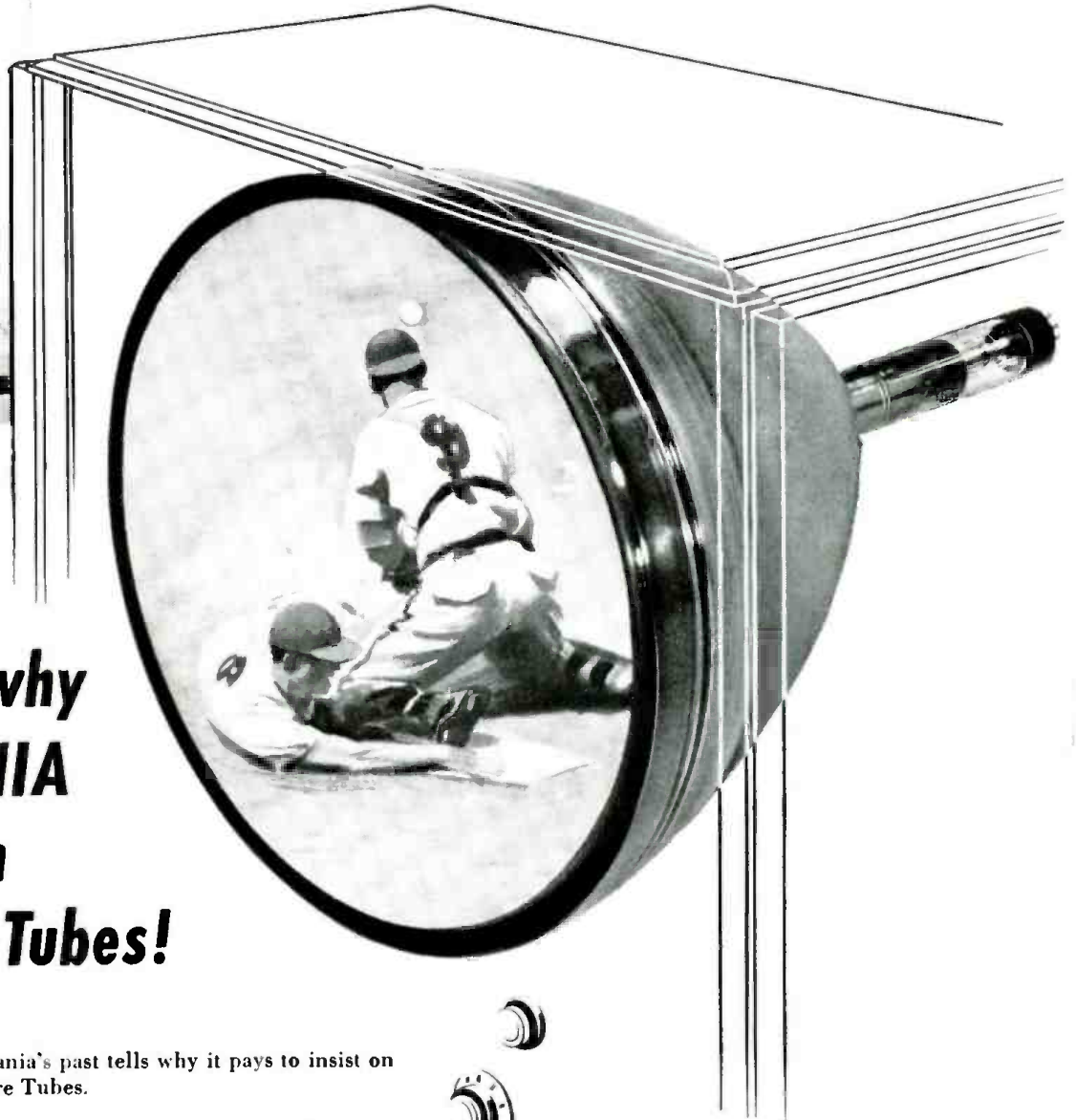

**That's why
SYLVANIA
leads in
Picture Tubes!**

A look at Sylvania's past tells why it pays to insist on Sylvania Picture Tubes.

Radio. For more than 25 years, Sylvania tubes have been noted for their fine performance and long life. Out of this experience has come a knowledge of electron behavior . . . clearer picture reception and Sylvania's famous ion trap now licensed to other leading picture tube makers.

Electronics. Sylvania's electronics background includes the designing of cathode-ray tubes, radar and other precision equipment for wartime use. From this has developed many of the modern advances in high-frequency techniques necessary for best TV reception.

Phosphors. In the development of phosphors for the "Finest in Fluorescent Lamps," Sylvania has been an acknowledged leader for almost 20 years. This spe-



cialized experience is a basic reason for the smoothness and uniformity of Sylvania TV screens.

Lighting. Over half a century of experience lies behind Sylvania's lighting leadership. This includes years of research in filamentary wire, coiling and coating processes . . . further important reasons for the clarity and long life of Sylvania TV Picture Tubes.

For illustrated catalog giving ratings and engineering data concerning all Sylvania TV Picture Tubes, address: Sylvania Electric Products Inc., Dept. R-2609, Emporium, Pa.

SYLVANIA ELECTRIC

RADIO TUBES; TELEVISION PICTURE TUBES; ELECTRONIC PRODUCTS; ELECTRONIC TEST EQUIPMENT; FLUORESCENT LAMPS, FIXTURES, SIGN TUBING, WIRING DEVICES; LIGHT BULBS; PHOTOLAMPS; TELEVISION SETS

THE INSIDE STORY: WHY SPRAGUE MOLDED TUBULARS OUTPERFORM ALL OTHERS!

Molded paper tubulars may look alike from the outside. But there's a whale of a difference inside—the part that really counts in the performance of your products.

The *exclusive* difference in Sprague molded phenolic tubulars is that: *each is made by the same dry-assembly process as large metal-encased oil capacitors.* They cannot be contaminated during manufacture!

Every Sprague molded tubular from 200 to 12,500 volts is molded *dry*. After molding it is impregnated under high vacuum through an opening in the eyelet terminal. A lead is then inserted and the terminal solder sealed. Result? A capacitor that offers you superior heat and moisture protection . . . top insulation resistance . . . high capacitance stability and retrace under wide temperature variations.

Small wonder then why Sprague molded tubulars are preferred for the toughest television and auto radio applications. Take advantage of this superiority by calling in a Sprague representative today. Or, write for Engineering Bulletins 210B and 214.

Hollow eyelet terminal for impregnation after molding

Solder seal as in large metal-encased oil capacitors

Non-flammable, dense bakelite phenolic-molded housing

CUT-AWAY VIEW

Uniform windings of high purity paper and aluminum foil

SPRAGUE[®]
PIONEERS IN

SPRAGUE ELECTRIC COMPANY
North Adams, Massachusetts

ELECTRIC AND ELECTRONIC DEVELOPMENT

TELEVISION ENGINEERING

LEWIS WINNER, Editor

September, 1950

The First Report

COLOR TV, wallowing in a raging sea of epithets for over a decade, appeared to be on its way to another tempest, as the FCC fired its views on the situation at industry, which stamped an interim approval on field sequential, the finality of which they said was up to industry itself.

In an opus, which many declared should have been entitled . . . *Let's See What Happens* . . . the Commission opined that cooperation by industry through their willingness to make sets with a 405-525 line switch, could delay adoption of the disc system until there was further investigation of the potentialities of other systems, and the prospects offered by large direct-viewing tubes, improved horizontal interlace and long-persistence phosphors. The Commission admitted quite bluntly, that there is greater activity now in the color field and that since fundamental research cannot be performed on schedule, it is possible that much of the fruit of this research is only now beginning to emerge. Thus, if the set makers play ball, the mechanical-scanning idea could become a subject of question, but if the switch plan was discounted, and industry refused to go along with the legislators, the 405 could become official.

A speculative decision was made, the FCC folks disclosed, because of *compatibility*, a term that seemed to have irked most of the Commission members since the proceedings began. Unless, they said, sets were now provided with the means to pickup the green signal, we would be running into a graver and graver compatibility problem, and perhaps it would only be possible to consider compatible systems. Industry, in their view, thus held the key to the next move. Oddly enough, little or no concern was expressed for the production of color sets themselves, a fact which prompted Commissioner Jones to say that . . . "the majority overlooks the fact that because the percentage of sets capable of receiving CBS color signals in black and white goes up, color is not promoted one iota". That the general thinking of the Commission was riddled with inconsistencies was also voiced by Jones, who noted that: "The majority decides that it need not further consider the development of long-persistent phosphors if a substantial percentage of black and white receivers hereafter produced do not contain bracket (405-525 line) standards. . . . The Commission, however, as a part of this decision, would *force* the industry to adopt bracket standards in black and white receivers without requiring any further proof or field testing of long-persistence phosphors."

Extremely specific reasons were cited by the FCC for their temporary choice of the field-sequential system. For instance, they pointed out that the line-sequential system failed, because it had a serious line crawl problem and the

picture texture was not satisfactory. They doubted the compatibility prospects of the system, stating that during the tests, there was evidence of serious degradation in the quality of the black and white pictures received from the system's color transmissions.

The dot-sequential system also failed, in the eyes of the Commissioners, because the color fidelity of the pictures available from this system were not satisfactory. In their opinion the dot-sequential pictures have a *soft* quality, probably due to a difficulty in maintaining contrasts, particularly in the small areas.

In the opinion of the Commissioners, the field-sequential system . . . "produces a color picture that is most satisfactory from the point of view of texture, color fidelity and contrast". The FCC noted that the susceptibility to flicker in the CBS system was greater than the present monochrome method, but they felt that the brightness achieved was adequate for home use. Their views on the color fringing and color breakup characteristics of the CBS system were interesting, revealing that: "In the first place, many viewers after awhile tend not to see these difficulties. . . . In the second place, these effects occur rather infrequently and many of them can be minimized by programming techniques. When they do occur, they are no more pronounced to the viewer than the stroboscopic effects in motion pictures". The Commission found that the CBS system had less geometric resolution than the present monochrome system, but they felt that the addition of color more than outweighed the loss in geometric resolution, insofar as apparent definition was concerned.

Explaining that it had not overlooked the testimony of many manufacturers who endorsed the dot-sequential system, the Commission cited that . . . "the responsibility for a decision is that of the Commission and we cannot feel bound to accept recommendations and expert opinions when we find from a study of the record, that the record supports different conclusions".

In the Commission's opinion, long-persistence phosphors offer a real bright hope in the continued development of color television. It was their belief that tubes featuring this characteristic would tend to reduce flicker substantially and provide a more useful color picture.

Since the report was issued, other color systems¹ have been announced and the designers have indicated that they would seek their day in the halls of Washington. If the switches go in, these newcomers, as well as the pioneering proponents, may have an opportunity to disclose what they can do for color TV. Thus, the next 120-days might see the color ring once more sizzling with contenders for that enviable standards' prize.—L. W.

¹ See page 8, this issue.

TVE-grams

The Management Front

Color or Else: The final days of September will long be remembered by industry, particularly, September 29th, or *CA Day**, when the FCC ruled that it must be told whether or not sets would include a manual or automatic switch which would make it possible to pick up standard telecasts or CBS color transmissions in black and white.

Some manufacturers were completely puzzled by the demanding tone of the Commission's statement and others felt that the bold move was required to set an immediate pattern for color planning. Scowling views were expressed by representatives of many mid-west chassis makers. In their opinion the decision was . . . "confusing" . . . "too hasty" and . . . "one of the most horrible blunders in the history of the Commission." There were those, however, who were quite enthused about the plan to go ahead with color, indicating that it's not too difficult to make the necessary changes, the concern over the technical aspects being over-emphasized. A few manufacturers, although quite disturbed, indicated that it would be their duty to protect those who purchased their sets and include the required switching systems.

The consensus among many TV set producers was that the hybrid monochrome TV sets, capable of receiving black and white programs under the 525-line standards and also under the 405-line standards as proposed by CBS, would be quite makeshift in structure. Others wondered, too, how it would become possible to adapt the 16 and 19-inch models, which are so popular now, to the CBS disc method. In official demonstrations, the 12-inch screen was the largest demonstrated by CBS. And no claims were ever made for a larger screen, except perhaps through the use of projection, which did not appear to have too much merit, even in the eyes of CBS' experts. The use of the 405-line standards also raised the question of an eventual transfer to the lower-lineage system, should the 405 approach become a standard. If color programs

were broadcast only under the CBS reduced-lineage method, and black and white pickups were made on 405, we might find that provisions for 525-line standards would no longer be necessary.

The specific designs that should be included in the adapter-type models appear to have confused many, too, not only from an electrical view, but from an economic standpoint. Specifically, the FCC has set up *bracket-standards* which provide . . . "for a television composite video signal of substantially the type and proportion now employed in monochrome, but with the number of lines variable from 15,000 to 32,000 per second, and the number of fields ranging from 50 to 150 per second. . . . Receivers should produce pictures of equivalent size, geometrical linearity and brightness on each of the two positions (for 405 or 525-line pickup) of the switch." According to one manufacturer, revising the present-day sets and equipping them with a manual or automatic switch so as to be able to select one of the two standards (15,750 lines in 60 fields and 29,160 lines in 144 fields) is not as simple a matter as it appears. Current models with their wide-angle scanning have been designed to meet a minimum price, so that actually they are operating at the very peak of their capabilities. To make the new models scan at higher line and field frequencies, it probably will be necessary to re-design completely, not only the scanning circuits, but perhaps some of the yokes. All of this effort will certainly mean a very substantial increase in the price of the receivers, which will not be accepted with too much enthusiasm by the consumer, particularly when he is told that he might have to wait quite awhile before color-monochrome programs become available in his area.

Generally, the bracket idea seems to have received a placid reception, with the time element and production-line problems cited as the immediate drawbacks to any wholesale acceptance of the switch-adapter plan.

*Color-Adapter Day.

(Left)

View of the tower of the Empire State Building, New York, as seen with a 40" reflector lens.

Improvised TV camera car constructed on a standard Chrysler New Yorker chassis. Wooden superstructure provides two shooting platforms for varied-angle photography. Lower platform folds into structure for over-the-road transport. The car was especially built to shoot outdoor motion picture sequences for commercials.



Reports and Reviews of Current TV News

Critical Materials: As General Bill Harrison's NPA swings into action, aluminum once more finds itself as a critical material slated for stockpiling. When the huge production programs were initiated during World War II, it was believed that never again would aluminum have to be considered as a metal short in supply. With ample sources of bauxite, the ore from which aluminum is obtained, and a tremendous finishing capacity available, it was estimated that unlimited supplies of the metal could be provided. However, the problem of primary aluminum supply has appeared and upset the cheerful prospects. Because of the lack of primary aluminum in pig and ingots, the finishing facilities of many plants have been idled.

Thus far, there have been only three domestic producers of primary aluminum, all of whom have found themselves taxed to capacity. Several factors have contributed to expansion delays. The huge quantities of electric power required to process primary aluminum has been the key drawback. In an effort to keep prices down, the aluminum makers have been purchasing power from government agencies. To increase production, more cheap power would be required and it is not all available where present plants are located. Plant expansion costs have been another factor. Requests for financial aid from Uncle Sam have met with little success.

Canada has been a heavy supplier of primary aluminum and probably will continue to be, unless an emergency arises in that country. There are plans afoot to import over 400-million pounds of primary aluminum in over a three-year period.

Some are looking to NPA for that nod on financial help which would provide the green light for expansion. Currently there is no danger that producers of military equipment will suffer from a lack of aluminum or that civilian supply will be curtailed too seriously for awhile. But, as the military begins to pour orders on to industry, more aluminum will be needed for all concerned. It is hoped that at that time, there will become available the Canadian supply and perhaps an

additional allotment from new plants which might be built.

The situation is brightened, to a degree, by the availability of magnesium, which is the only major structural metal that is not on the Munitions Board's list of strategic and critical materials. It is reported that there is an unlimited supply of the raw materials from which magnesium is extracted. The metal appears to have endless applications for not only machine work, but for electrical equipment. It has been, for instance, successfully used as a supporting framework for microwave reflectors. House-top antenna makers have also found the metal extremely satisfactory in a variety of instances. It appears to be a material which has enormous possibilities, particularly in view of the emergency which we face today.

Procurement: The five-per centers are now being rapidly replaced by the streamlined purchasing procedures developed by the Department of Defense and the Commerce Department. Today, for instance, it is possible to secure vital bid information in over 1500 locations throughout the country, the addresses of which are available from Commerce Department offices in any one of forty-eight major cities. In addition, there are a variety of helpful publications with purchasing data which have been issued by the Army, Navy and Air Force and the Department of Commerce. These publications include a *GSA Supply Report*, available from the Federal Supply Service Inquiry Office (General Services Administration, 7th and D Streets, Washington 25, D. C.); *Index of Military Purchasing Offices*, available from the Munitions Board, The Pentagon, Washington, D. C.; *Guide For Selling to the U. S. Air Force*, available from the Commanding General, Air Materiel Command (Wright-Patterson Air Force Base, Dayton, Ohio (Att. MCPAXC)); *Selling to the Navy*, available from Superintendent of Documents for 15c, and *How to Sell to the U. S. Army*, also available from the Superintendent of Documents for 30c. General information can be obtained from the Military Procurement Information Office, Room 3-D-773, The Pentagon, Washington 25, D. C.

A 30-inch metal-cone picture tube, produced by DuMont, serving as a table top during a press party at which the tube was announced. The tube was developed under the direction of S. J. Koch, manager of the tube laboratory of the DuMont research division which is headed by Dr. T. T. Goldsmith, Jr. The screen of the tube has more than two and a half times the area of the 19" type direct viewing tube, providing 536 square inches of picture area. Tube employs a 90° deflection angle and is shorter in length than in diameter. This makes it possible to house it in a cabinet of convenient and conventional size.



A Baldwin 10,000-pound wire testing machine, in use at Western Electric's Hawthorne Works in Chicago. Samples of all copper line wire produced, as well as samples of copper rod from which wire is drawn, are tested by this machine.

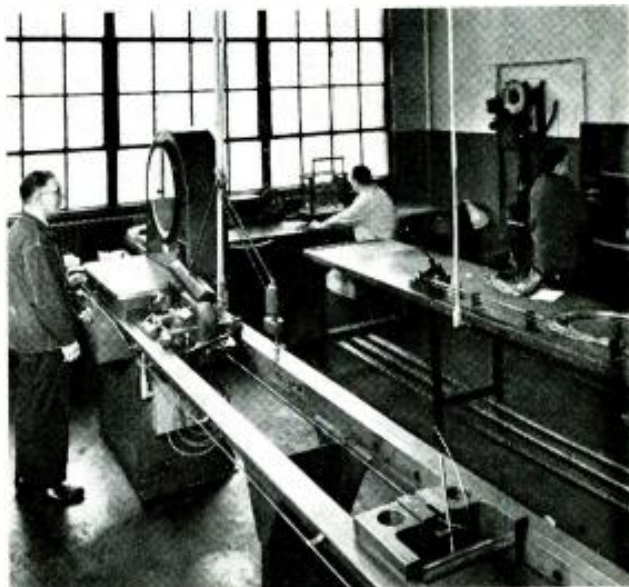

Research

New Systems for the Reds, Greens and Blues: In the color race now are two new systems, one using *dash-sequential* and the other *frequency interlace*. The dash-sequential approach, developed by CTI and called a *uniplex* system, is said to have a line and field rate identical to standard black and white. In its petition to the FCC, CTI said that . . . "Brightness should be superior to that of the other proposed color television systems, using the same types of direct view tubes, since the duty cycle of such tubes, as used in the *uniplex* system, approaches 100%."

The *frequency-interlace* system, proposed by G.E., which is said to be free of twinkle, crawl, flicker, color shifting and of field-sequential color fringing, is based on a premise of physiological filtering or the viewer's eye's persistence of vision. In an explanation of this filtering concept, G. E. reported that if . . . "arrangements are made so that only two color signals are applied simultaneously to one picture-tube grid, the undesired signal will alternately add and subtract from the desired signal at frame frequency, and its effect will be essentially filtered-out physiologically, that is, by the persistence of vision in the viewer's eye."

The *constant-luminance* development, at Hazeltine, which reduces shimmer and crawl in TV images, when applied to the dot-sequential method, has been cited as another important contribution which cannot be dismissed in the all-out effort to obtain an adequate color system.

Theater TV: With the processing of giant TV mirror blanks, measuring 26" in diameter and 2" in thickness, it will soon be possible to install on a wide scale, theatre TV projectors which will provide wide-angle bright pictures 15 x 20 feet in area. These huge blanks, cast by the McKee Glass Company, are finding their way into Schmidt-type reflective optical systems.

Direct Reading RF Wattmeter: From the NRL has come a unique instrument which provides for the measuring of *rf* power from 30 to 3,000 microwatts. Instead of the *ac* substitution method employed by many types of wattmeters for measurement of *rf* power, the new type makes use of a *dc* movement meter and precision resistors (thermistors) to achieve an accuracy of 4 per cent or better over its power-measurement range.

A thermistor is placed in one arm of a bridge circuit whose other arms are usually 200 ohms each. A given amount of *dc* current is passed through the bridge and an adjustable *ac* voltage is connected and varied until the bridge is balanced. When *rf* power is applied to the thermistor, the *dc* current is automatically reduced until the bridge is again balanced. Since the bridge is again balanced, the change in *dc* power in the thermistor is equal to the *rf* power. A meter circuit is arranged to read this change directly.

Although this instrument was first intended for use in power monitoring work, other uses for it have arisen, such as that of checking signal generator output. The instrument was developed in *Radio Division Two* of Naval Research Laboratory.

The NRL direct-reading *rf* wattmeter for measuring 30 to 3000 microwatts.

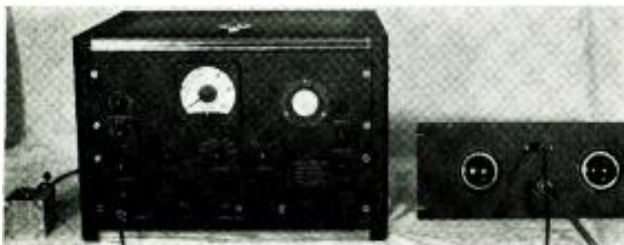

Ceramic Lighthouse Triode: Now available is a high G_m miniature ceramic planar triode, which can be used as a microwave amplifier, oscillator, frequency multiplier or detector. The tube, developed by Machlett, has a remote upper frequency limit in the neighborhood of 6000 mc, and in a class *A*, amplifier-grid separation circuit has an amplification factor of 85. No glass enters into the construction of this tube. The elimination of glass permits outgassing during evacuation to higher temperatures than heretofore. The tube is 2 5/16" in height and at its widest point is 15/16" in diameter.

Materials and Methods

Ideal Tape: In a report covering several years of research on electrical impregnating varnishes which will withstand extreme atmospheric and climatic conditions, released through the Office of Technical Services in Washington, D. C., the features of an ideal tape have been described. We are told that such a tape should be an inorganic, non-corrosive and non-hydroscopic product that will remain flexible from $-55^{\circ} C$ through $+150^{\circ}$, and mechanically and chemically stable at the latter temperature. The tape, we also learn, should possess high dielectric strength throughout a wide range of temperatures and humidities, and should be compatible with the varnish selected and any fungicide used with it.

Silicone Resins: Silicones which can be employed as coatings on glass cloth and sleeveings, as well as for bonding and impregnating motors and transformers, have been developed recently in the chemical laboratories of G. E. One resin, a flexible type of substantial drying speed requiring no catalyst, has been used effectively as a coating on glass cloth and glass sleeving and as a sticker for mica-glass tape and other flexible mica products. It is available as a 60% solution in toluol. The other resin, supplied as a 50% solution in petroleum spirits, can be used for bonding and impregnating motors, generators and transformers requiring a class *H* insulation, and in addition may also be used in bonded mica, mica tape and glass combinations. Tests have indicated that it will through-cure readily and develop good bonding properties at elevated temperatures. It can be used as furnished, without a catalyst.

Organic Coating for Resistors: The *shelf* and *service* life of resistors are said to have been extended through the use of an organic cement coating which, when applied to resistor-wire, which is space wound on low-loss ceramic tubes, produces high stability for the resistance winding and offers maximum protection against moisture, humidity and electrolysis. According to the Wirt Company, who are making these resistors, the coating may be applied to fixed, adjustable, ferrule and Edison base styles of resistors.

Thinner-Than-Hair Steel Wire: A super-thin alloy, which is only .00025 inch thick, has been developed for the Navy for magnetic-wire applications. A product of the research lab of Armco Steel, the magnetic alloy wire strip is elongated 400 times before it is reduced to the required thinner-than-hair thickness. To test the performance of these alloys, it is necessary to slit two-inch strips into ribbons one tenth of an inch wide on a jig which uses razor blades as cutters. The ribbons are then coated, wound into tiny coils and annealed. During one run, it was found that four test coils of the ribbon weighed so little that 2250 such orders would yield only one pound of metal. An aspirin box and first class mailing sufficed as the shipping means for this coil run.

Production Control

VHF Calibration Service: Now available through the facilities of the Bureau of Standards is a calibration service for 30 to 300-mc field intensity meters. In this field intensity operation, the Bureau employs two experimental methods: standard antenna method and standard field method. It has been found most practical to use the standard antenna method for frequencies greater than 30 mc and the standard field method for lower frequencies. In calibrating a commercial *vhf* field-intensity meter by the standard-antenna method, the field strength at some arbitrary distance from a special *vhf* transmitter is determined by a standard receiving antenna, employing a crystal voltmeter. The antenna of the commercial set is substituted at the same position. Knowledge of the field strength, the height of the antenna above ground, and the meter readings obtained with the two antennas permit computation of the coefficient that must be applied to the commercial instrument to relate field intensity. In the standard-field methods used at frequencies below 30 mc, a known induction field produced by a single-turn transmitting loop antenna is used. Relatively short distances are employed between the transmitting and receiving loops so that reflections from the ground and nearby objects are minimized. The antenna coefficient of a commercial meter placed anywhere in the known field can be calculated on the basis of the known field strength and the distance between the two antennas.

The Production Line

Speed-Nut Clamp: A clamp which serves in some cases to mount a deflection yoke to the hood and where powdered iron cores are used, clamp the cores in position, recently became available. The clamp, produced by Tinnerman Products, is said to provide a solid support for the yoke and picture tube, thus minimizing the danger of misalignment and broken connections which frequently result from rough handling during shipment. Mounted to the hood, the clamp is tightened by a No. 6-Z screw which fits a *speed-nut* impression formed into the clamp. Opposite the clamp opening is a channel housing a *speed-nut* which serves as a floating nut retainer and also provides the resiliency required to hold iron cores securely, but not rigidly.

Pressed-Fit Pin: A self-locking pin with chamfered ends has been engineered to replace the dowel, pivot, tapered and grooved pins which ordinarily require a key or some supplementary fastening method to hold them in place. Known as the *Rollpin*, it is a piece of metal rolled into the shape of a cylinder with a gap or slot which parallels the long axis of the hollow cylinder. Both ends of the cylinder are chamfered, or beveled, so that the pin can be driven and compressed into a hole that is, by design, smaller than the diameter of the pin. The slot permits compression of the cylinder as the pin is driven in, and the resulting tension, caused by the constant pressure exerted by the *Rollpin* against the walls of the hole, secures it in position against abnormal vibration and shock. The pin can be inserted with hand tools or automatic jig assemblies and removed by driving it out with a drift pin or pin punch.

Currently the pins, produced by Elastic Stop Nut Corp., are being used in a TV 35-mm projector.

Standards: To aid users in the proper selection and purchase of flexible tubular products for electrical-insulation purposes, NEMA have prepared a set of new standards which contain information on the classes, grades, color, appearances, length, tolerance on cut pieces, inside diameters and the measurement of flexible varnished tubing and saturated sleeving.

Good Reading

Slotted-Cylinder Antennas: An excellent report on the input impedance of a slotted-cylinder antenna has been prepared by Charles A. Holt of the University of Illinois. The slotted-cylinder antenna, which has become quite popular in FM broadcasting, is now being widely experimented with in TV. This report presents an analytical method for determining the input impedance of the antenna in terms of the dimensions and wavelength. (Slotted cylinder antennas consists of a hollow metal cylinder with a thin axial slot connecting the interior and exterior regions. The slot is short-circuited at both ends with the feed voltage applied across the slot at its center point. The ends of the cylinder may be either open or closed). The method is applicable only for diameter-wavelength ratios less than about 0.2, but we are told this limitation does not exclude the most useful frequency range.

Shielded Rooms: In a thorough review of the design, construction and evaluation of shielded rooms, G. A. Morgan Jr., of the Naval Research Laboratory, has revealed many new concepts for shielding which should prove helpful in constructing cages for production and laboratory activities. The report is being distributed by the Office of the Publication Board in the Department of Commerce, Washington 25, D. C.

Trends

TV Houses: Architects appear to have become quite TV conscious. Whereas in the past the general plans for a small home included only consideration of such prosaic problems as windows, fireplaces, the porch, closets, etc., we now find the TV receiver a factor in the blueprints. In a series of houses recently designed for construction on Long Island, a special TV niche has been included in the living room layout, which, according to the architects, permits maximum viewing of the television screen from practically anywhere in the room. The house has been tagged as . . . *a home for the video age.*—L. W.

Tubes of *perma-tube* which employ the *fitted-joint* feature for TV antenna masts. Tubes are now available in lengths up to 10 feet, diameters up to 4 inches o.d. and wall thickness up to 10 gauge. Tubing is steel *electricweld* type with a rust resistant vinyl plastic finish. Coating makes a chemical bond with the surface of the steel.

(Courtesy Jones & Laughlin Steel Corp.)



Evaluating Video Bandwidth and Picture Quality

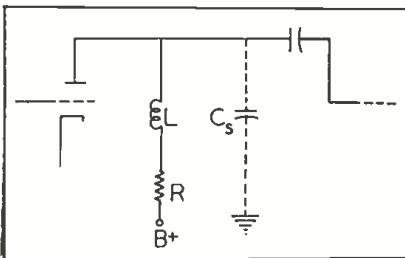

Figure 1 (a)
Shunt-compensated video interstage.

by M. A. HONNELL and M. D. PRINCE

Electrical Engineering School Mathematics Department
Georgia School of Technology

THE QUALITY AND LIFELIKE appearance of a television picture has been found to be greatly affected by the video bandwidth of the complete TV system. Although government regulations permit the use of a maximum video bandwidth of 4.5 mc by commercial stations, questions are frequently raised concerning the effect of a restricted transmission band on picture quality. For example, to what extent should the available bandwidth in a receiver be sacrificed in the interests of economy? Could a less expensive low-resolution system be employed to view a certain industrial process? Is the quality of a televised program degraded appreciably if a transmission circuit with a bandwidth of three megacycles is used for picture transmission?

Due to the complex psychological factors involved, it becomes apparent that the answers to these problems can best

be determined experimentally, for even though the phase, frequency and transient responses of a video system are known, it is most difficult to determine analytically the ability of the system to reproduce a typical dynamic scene containing fine contrast gradations.

Bandwidth Control

In making an experimental study of the relation between the bandwidth and picture quality, it has been found desirable to vary the overall bandwidth of the television system in discrete steps and to evaluate its performance under each bandwidth condition. For a single video stage, this desired change in bandwidth can be readily achieved by an unconventional application of standard shunt-compensation techniques. When shunt peaking is employed in the usual manner to extend the high-frequency

response, an inductance is used, as shown in Figure 1a, to compensate for the effect of the stray capacitance which shunts the load resistance of the stage.¹ The value of this inductance can be determined from the expressions,

$$f_o = \frac{1}{2\pi RC_s} \quad (1)$$

$$L = \frac{NR}{2\pi f_o} \quad (2)$$

where f_o is the upper half-power frequency of the uncompensated amplifier stage, R is the load resistance, C_s is the stray capacitance, L is the compensating inductance, and N is the design parameter which determines the frequency, phase, and transient responses of the stage for a given value of f_o .

These design equations and the same circuit configuration shown in Figure 1a

Figure 3a
Original photograph of subject used for transmission under bandwidth conditions shown in Figure 2.



Figure 3b
Reproduction of photo under condition A in Figure 2.



Figure 1 (b), below
Modified shunt-compensated video interstage.

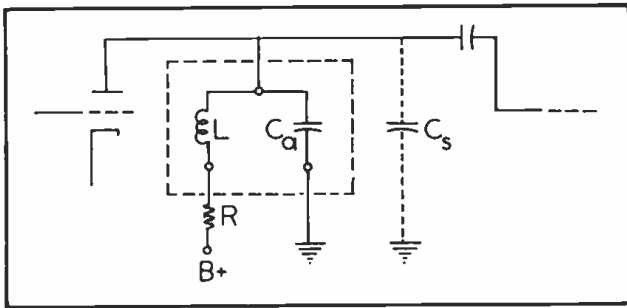
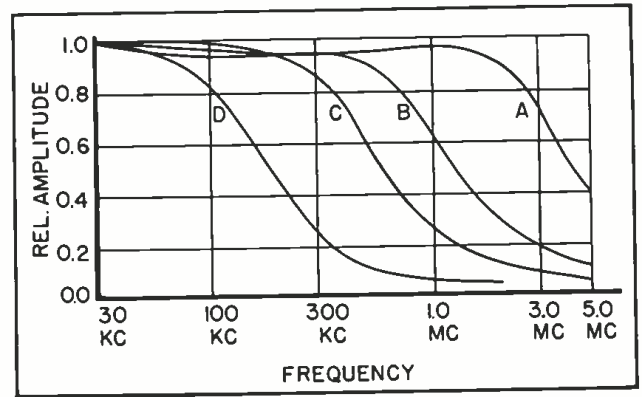

Figure 2
Frequency response characteristics for modified stage under four bandwidth conditions.



Modified Shunt-Compensated Video Interstage Analysis Method Permits Control of Bandwidth so that Test Material Can Be Observed and Transmission Quality Evaluated. System Reveals Extent the Bandwidth in a Receiver Can Be Decreased.

may be adapted to *reduce* the width of the pass band of the video stage and yet retain the best frequency and phase responses within the reduced pass band. The reduction of the bandwidth can be readily accomplished by increasing the apparent stray capacitance of the stage by shunting an added capacitance C_a from plate to ground. The desired frequency and phase characteristics are then obtained by use of a peaking inductance to compensate for the effect of the total shunting capacitance. This circuit is shown in Figure 1b and the modified design equations obtained from (1) and (2) are

$$C_a = \frac{1}{2\pi R f_o} - C_s \quad (3)$$

$$L = \frac{NR}{2\pi f_o} \quad (4)$$

where C_a is the added capacitance and C_s is the stray capacitance of the video stage. The proper value of N is selected by examination of families of universal curves which give the frequency, phase, and transient responses of single-stage and multi-stage amplifiers.² A value of $N = 0.5$ results in a satisfactory response for the compensated stage. For the choice of $N = 0.5$, the response

does not drop below 60% of the mid-frequency response out to a frequency of twice f_o .

By use of the design procedure just described, a single video stage can be modified so that it exhibits the specified restricted bandwidth and the desired response characteristics. Furthermore, since the frequency response of an amplifier chain is the product of the frequency responses of its separate stages, the bandwidth of the complete video system may be controlled by modifying the bandwidth of this single video stage, provided the remainder of the system is
(Continued on page 19)

Figure 3c

Reproduction of photo under condition B in Figure 2.



Figure 3d

Reproduction under condition C in Figure 2.



The ORTHOGAM Amplifier

by E. DUDLEY GOODALE
Staff Engineer, NBC



Front view of amplifier, which is complete with a self-contained power supply, mounted on a chassis approximately 5" high x 15" wide x 9" deep. Power consumption is 110 v at approximately 1.2 amperes.

Tone Correction Non-Linear Amplifier, Affording Greater Amplification to the White Portion of the Picture Signal than to the Dark Portion, Provides Appreciable Improvement in the Overall Tone Rendition of Normal Film and Films of Picture-Tube Recordings.

ONE OF THE MOST COMMON CRITICISMS of the picture quality of motion picture film reproduced over a normal TV chain using an iconoscope as the pickup tube is the washed-out appearance of the white portions of the picture. Faces appear chalky and have no half-tone quality. There is little, if any, separation between the white and near-white portions of the reproduced images. This is particularly true when using picture-tube recordings as the source of film material.

Many times this effect can be minimized by the use of special prints having well chosen density ranges and carefully controlled processing of the films, both negative and positive. The lighting used in the original photography can likewise have a very appreciable effect on the resultant tone quality as reproduced over the television system. Unless extreme care is exercised in the photography and in the film-processing method, considerable departures from a reasonable reproduction of the original scene can easily result.

The film iconoscope and the picture-

reproducing tube are far from ideal, in so far as providing a faithful reproduction of the tone quality recorded on the film. Both the film processes and the iconoscope/picture-tube combinations generally have characteristic S shaped transfer curves when plotted on a light-in versus light-out basis. The overall gradient is low in the dark portion of the scenes, increasing to a maximum, and then falling off again to a low value in the extreme whites. This manifests itself as a compression, as it is sometimes called, of the black and white portions of the original scene and a lim-

Left, top view, and right, rear view of amplifier. A minimum input signal of .5 volt peak-to-peak is required for the amplifier, which will deliver up to a maximum of approximately 2 volts, peak-to-peak output.

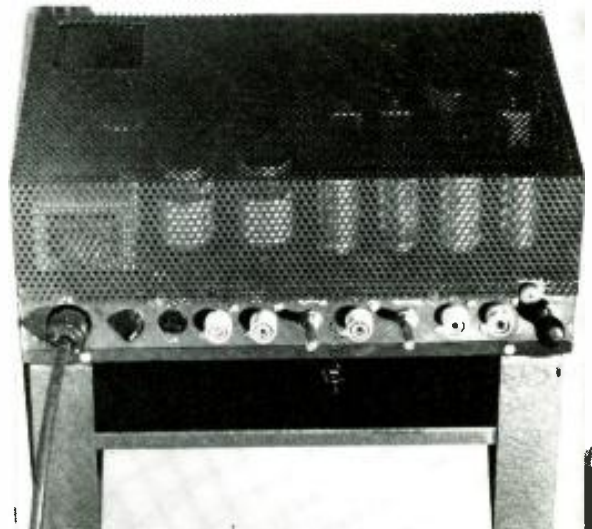
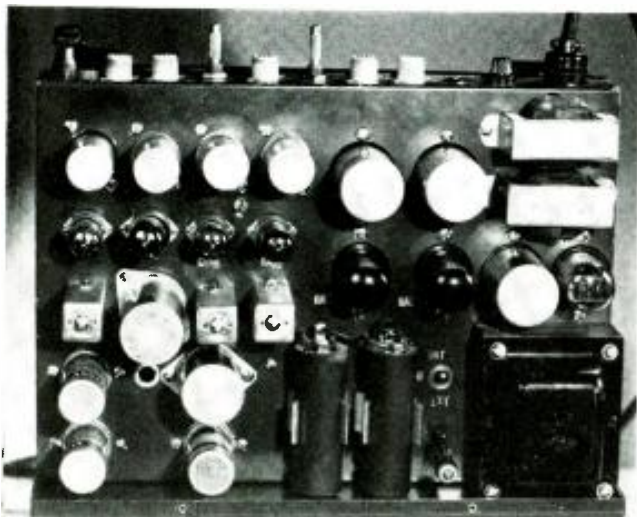

itation of the brightness range over which fairly good reproduction is possible.

These defects have long been recognized and have, in fact, been discussed in several papers.^{1,2} When going through a single process, such as a normal negative-positive film, the effect of a lower gradient in the extremes of the tone ranges than in the center part is not too objectionable, if one is careful to control exposure and film processing. Likewise, the single television pickup and reproducing tube combination can give very acceptable results under carefully controlled conditions over a limited range of light values. The trouble arises when an attempt is made to run the two in tandem. The range and relative gradients are much more difficult to handle and the problem becomes more complex. Even so, reasonably acceptable results can still be obtained if sufficient care and time are expended to control both the film and television system. An added complexity arises when an attempt is made to photograph the original scene, as reproduced via a television system, and retransmit it as film program material. The results are often quite disheartening. The range is further limited and the gradient distortion is further increased. Such is the condition which exists in the case of picture-tube photography. To make matters worse, the incoming signals vary tremendously from camera to camera and from scene to scene. Generally speaking, in picture-tube photography of commercial television shows, one has to take the signal as it is delivered to the recording facilities.

It has been found possible to obtain an appreciable improvement in the overall tone rendition of normal film and films of picture-tube recordings with a device which has been named the *orthogam amplifier*. This is a non-linear 6-tube amplifier which affords a greater amplification to the white portion of the picture signal than to the dark portion. It is used in conjunction with a normal chain of iconoscope film-pickup equipment.

The first two stages of the unit are conventional video amplifiers having a combined gain of approximately 12. An input gain potentiometer is employed to control the level of the video voltage reaching the grid of the first tube. This should be approximately .5 volt peak-to-peak and may be conventionally measured at the pin jack located adjacent to the input level potentiometer at the rear of the chassis. The second half of V_{53} , a dual triode 12AT7, is connected as a *dc* restorer across the

(Continued on page 26)

¹Fink, D. G., *Brightness Distortion in Television*, Proc. IRE, June 1941.

²Schade, O. H., *Electro-Optical Characteristics of Television Systems*, RCA Review; Vol. IX, 1948.

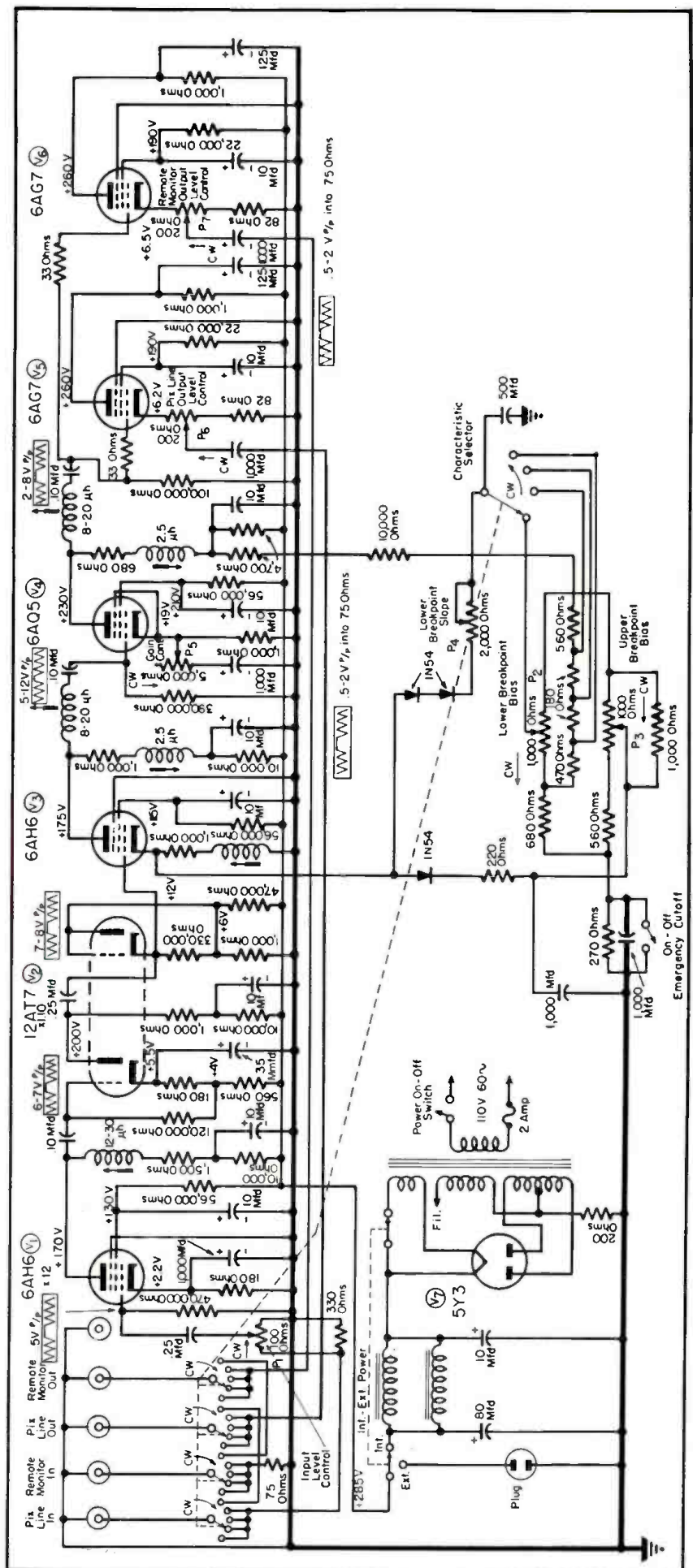

Circuit of the amplifier, a 6-tube system, with an overall frequency response that is flat to 7 mc.

Meeting the Audio

Practical Tests and Measuring Equipment Which Can Be Applied to the Audio System to Determine Signal Voltage, Response, Distortion, Frequency Discrimination, Noise Level and Hum, and Locate Defective Components, Including Capacitors, Resistors, Audio and Driver Transformers, Etc.

WITH THE FCC now requiring proof-of-performance on license renewal, many station engineers are finding to their surprise that their station does not meet specifications. Not having test equipment to make regular checks, the deterioration has been so gradual as to be unnoticed by aural detection. Frequently, an engineer is retained to make the measurements, and while he is willing to cooperate fully with the station engineer to establish satisfactory performance, the night may be well advanced before the complete story is known. Corrective components may not be obtainable at that hour. The field engineer may have a schedule to work at another station the following night. The net result has been that stations have paid a considerable sum to learn that distortion or noise is high or response is poor.

Actually, the FCC rule implies that broadcast stations should obtain and use distortion measuring equipment. The station may obtain such equipment and measurements indicate unfavorable results, but there appears the difficulty of diagnosing the factors which might contribute to the poor performance.

The audio system is the key factor in the tests. In a high-level modulated transmitter the audio setup is nothing more than a high-quality amplifier capable of delivering from 150 watts for a 250-watt transmitter to 30 kw for a 50-kw transmitter. The principles in each

are the same, the latter naturally requiring more stages. It would probably be safe to say that invariably the audio system of a transmitter is in push-pull. An input transformer brings the signal into the audio system and a modulation transformer couples the load to the output. The audio driver couples to the modulator by one of several methods predicated on the tube lineup, and the manufacturers' preference. Any stages between the input and driver are most generally resistance coupled. In low-power transmitters, the input stage may actually be the audio driver stage.

Prior to the official measurement tests, the use of a series of preliminary checks will be found very helpful in isolating and curing many system defects. In this work equipment used can include a voltohmmeter and a vacuum-tube voltmeter, the latter being more effective since the signal voltages can be measured without frequency discrimination. A scope has also been found very useful, the wave shape providing clues as to the type of distortion existent. It is also necessary to have signal-source equipment such as an audio oscillator. Lacking this, a substitute can be made using a receiver transformer or filament transformer which has an ungrounded secondary filament winding. A standard 500 to 500,000-ohm volume control connected across the filament winding, can serve as a gain control.

As mentioned, transmitter systems are almost without exception, in push-pull. Feedback is generally used. In some transmitters it is required to obtain satisfactory performance; in others it is used to obtain supplementary improvement. The stages included in the

feedback loop vary considerably with the make and model of transmitter. In typical transmitters of 5 kw and higher, feedback is taken from the plates of the modulators through a resistance-capacity network back to the grids of the input stage. In one model, feedback is around the single audio driver stage used in this transmitter. Other systems may take from the modulator plate to the driver grid. Again, there may be a feedback loop inside the main feedback loop; or the main feedback loop may branch and not only feed back to the input stage, but also to the driver grid, or some other point.

With the transmitter functioning normal, step-by-step signal voltage measurements should be taken through the audio system, preferably with a vacuum-tube voltmeter. For a given percentage of modulation, the grid of the first tube should have very close to the same signal voltage as the opposite grid. By measuring on the grids of the tubes, plate voltages will be avoided. With resistance coupling, the signal voltage on the grid should be the same as the signal voltage on the plate of the preceding tube. When the modulator grids are reached, it is then necessary to block the bias voltage from the meter. A multiplier-*dc* blocking unit can be employed for this purpose. The capacitor used for blocking should have a

Figure 1
Substitute or emergency oscillator, featuring a filament transformer with a volume control for adjusting gain.

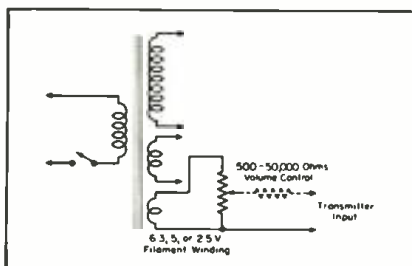

¹Gates BC-250-GY.

Figure 2
Feedback may be employed around the audio driver stage only as indicated here. Besides reducing distortion, the feedback is used for response control.

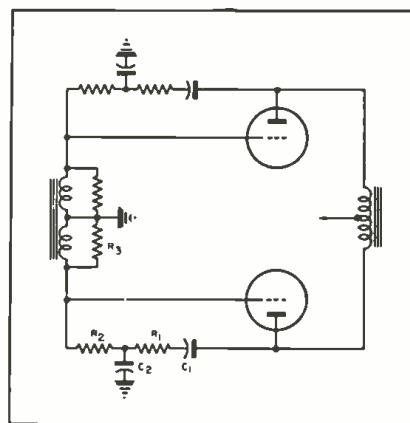

Requirements in Proof-of-Performance Tests

by **L. B. PETERY**, Transmitter Design Engineer, Gates Radio Company

working voltage of the highest *dc* voltage in the unit, and the capacity should range from .002 to .1 mfd. The lower capacity has been found to be better since there is less transient surge on the measuring equipment when the probe is connected on a *dc* source. However, in measuring the response there will be a loss on the low frequencies. The resistors in the unit can be of the 1-watt type, from .1 to .25 megohm and preferably of equal value. In the unit illustrated in Figure 3a, the range has been extended four times. The arrangement shown in Figure 3b has been found useful in converting a single-ended distortion meter or scope to a bridging arrangement. Here, too, the fixed resistors can be 1 watt type with .1 to .25 megohm ranges, while the potentiometer can have a .1-megohm value. The transformer preferably should be a regular bridging transformer, but lacking this, the best possible substitute, such as a tube to line unit, will do.

Either the voltohmmeter or vacuum-tube voltmeter can be used to measure the signal in *rms*. The peak signal voltage will be 1.4 times the meter reading, and generally the peak grid voltage should not exceed the bias volt-

age. This condition will hold with any class *A* amplifier, but not necessarily with class *AB* or *B* stages.

In testing, if an appreciable difference in signal voltage exists between the two sides of a push-pull stage, it will be necessary to investigate the difference. With the feedback loop in the circuit, this feedback will try to overcome any fault present. To locate properly the fault the feedback should be disconnected. In opening the feedback loop, it is necessary to be certain that the correct break-point is selected. Otherwise full modulator plate voltage might be placed on the low-level audio components. Any secondary feedback loops (branches from the main loop) should be similarly disconnected.

After this test has been completed, the audio can be rechecked. The input level will be found to be reduced in proportion to the amount of feedback used. If an unbalance existed previously, it will appear again, this time in the stage at fault. By reversing the tubes side for side, if a faulty tube is present, the unbalance will appear on the opposite side.

In hunting distortion and making measurements, particular attention

should be paid to the tubes which often are the cause of the trouble. In this check, each tube should be carefully marked for original position, so that it will be possible to select the defective tube, as the tubes are switched around.

The power-amplifier stage (high level modulation; low-level modulated transmitters must be considered differently) should also come under scrutiny. An improperly functioning tube here may introduce characteristics, into both audio and radio circuits, which may cause excessive distortion. The best plan is to start with the input stage and follow through to the output.

Capacitors have been found to be an insidious source of trouble. Often, there is no external indication of either short or open circuit. Thus, a bypass which does not bypass, such as on the screens of a pentode or beam power stage, will introduce considerable distortion, in this case, on the high-frequency end of the spectrum. A capacity meter will be found to be a valuable tool in this probe. Every capacitor should be measured for capacity and leakage, and any which do not reasonably approximate the given value, should be replaced.

[To Be Continued]

Figure 3

In (a) appears circuitry of a multiplier which can serve to extend the range of a meter, a blocking capacitor used to check circuits containing *dc* voltages. In (b) is a circuit of a bridging arrangement for single-ended distortion meters or scopes. Permits making grid-to-grid measurements in push-pull amplifiers.

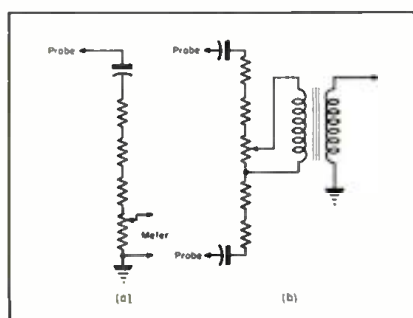
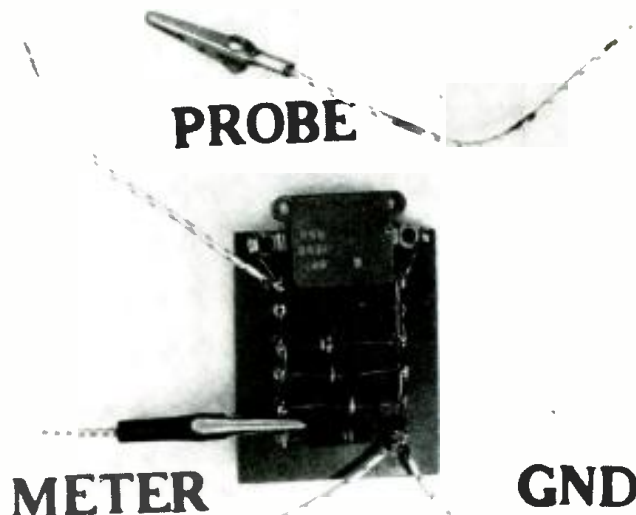
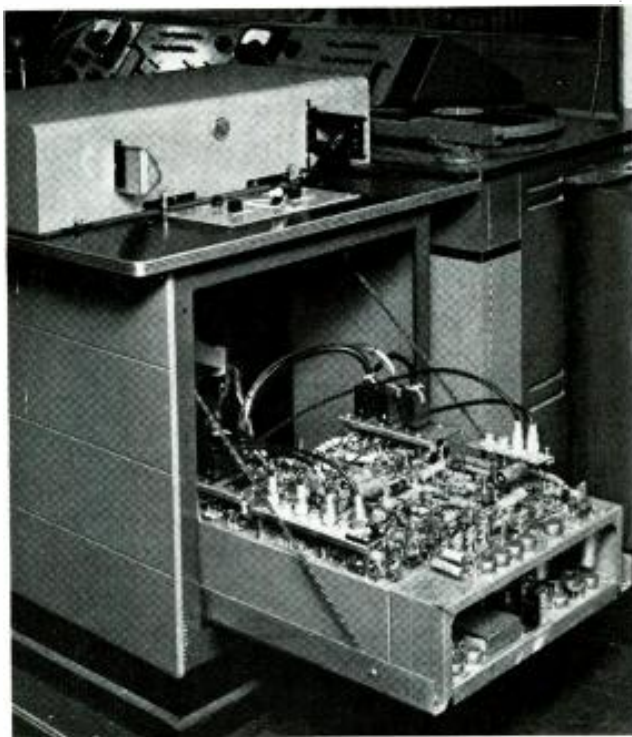
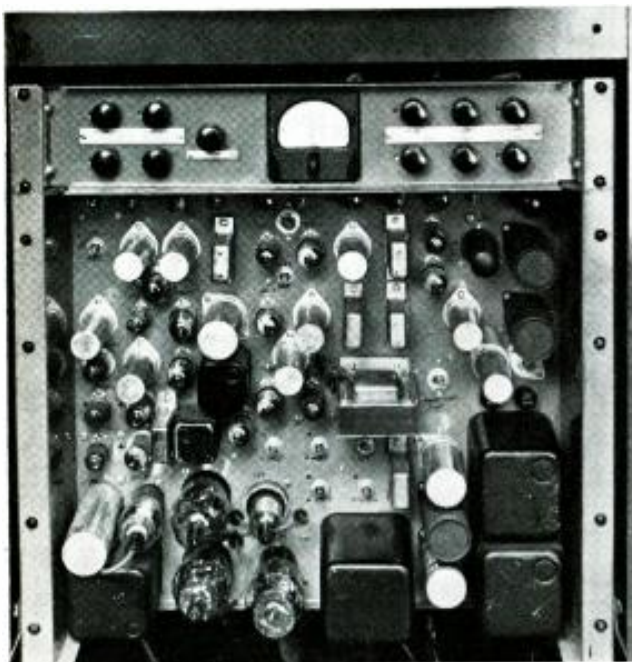

Figure 4
View of the multiplier
diagramed at left.



(Below)
The camera's removable front panel providing accessibility to tubes.



(Above, right)

View of camera unit with front cover removed, and with video and deflection chassis hinged down to make wiring and small components accessible. The various controls needed for setup and occasional adjustment appear on this chassis. Those which might be needed from day to day, such as beam current, centering, size, etc., are mounted on a narrow panel at the top of the chassis and are accessible through an opening in the front cover. A meter which may be switched to read picture tube beam current or high voltage is located on this panel. Other controls such as linearity and compensation, which are normally set and locked are located on the chassis itself. All power connections to the main chassis and between this chassis and the mixer and preamp chassis are made with plugs to facilitate disassembly for service. All video connections are made through standard coax connectors.

output to the other. Also, the two levers comprising the fader mechanism may be operated together for lap dissolve, or separately for fading and superposition.

Typical Applications

One need only observe the operation of a typical television station to see many possible uses for the flying-spot camera. Test pattern is normally carried for many daytime hours, and is usually originated either in a monoscope with a special call letter picture tube or a slide projector and film camera. The flying-spot camera can supply this test pattern and in addition offer a variety of material for station call, commercials, or special occasions. In TV stations where film cameras are normally tied up for these operations, the addition of the flying-spot camera would free them for use in rehearsals, previewing, or maintenance. These considerations are probably most valuable in the studio, but would apply equally well when the transmitter site is at a distant point from the studio. Then, too, the small station with only a network program source would find the flying-spot camera very useful for inserting local announcements.

Program Possibilities

For actual program use, the turntable kinship mentioned before offers flexibility in application. For instance, with every dramatic production, a list of

characters is presented. This could easily be handled with the flying-spot camera while a studio camera, normally used for the purpose, would be freed for other uses. In the same way, short commercials, announcements, weather reports, or phone numbers may be setup, shown, and put away with a minimum of complications.

Studio Setup

In a typical setup of the flying-spot camera in a studio, a video control console can be mounted, let us say, to the right. Thus, the flying-spot camera would be located beside the operator just as the record turntable is located beside the audio operator whose console is to the left.

Special Effects' Uses

The flying-spot camera can also be used with the *special effects equipment*.* By means of a special mask

assembly which may be fitted into one of the slide holder channels and actuated by an external lever, mask signals for the *special effects* keying may be generated. Infinite variety is possible, both for fixed cutouts, or wipe effects when the sliding mask assembly is moved across the scanned area. The mask assembly is shown inserted into the right hand slide holder position in several of the illustrations.

*Recently developed by RCA.

View of the two, six-space slide holders which allow twelve slides to be shown in succession.

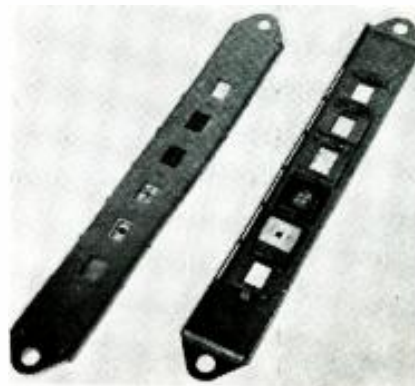

Video Bandwidth

(Continued from page 11)

linear out to a sufficiently high frequency.

Illustrative Example

The foregoing design procedure was probed in an investigation of the performance of a wired television system which utilized sequential scanning of 350 lines per frame, 40 frames per second, and had a video bandwidth of approximately 2.5 mc. It was desired to test this system under four different bandwidth conditions, indicated in the second column of Table I.

To control the bandwidth of the video system, a resistance-coupled 6AC7 video amplifier in the monitor was selected as the stage to be modified. This stage had a load resistance of 1,000 ohms and a stray capacitance of 40 mmfd. By application of equations (3) and (4), the following values of L and C_s were obtained using the suggested value of $V = 0.5$:

$$(V = 0.5 \quad R = 1,000 \text{ ohms} \quad C_s = 40 \text{ mmfd})$$

Condition	f_c	L	C_s
A	1,500 kc	53 uhy	66 mmfd
B	500 kc	159 uhy	278 mmfd
C	200 kc	398 uhy	756 mmfd
D	75 kc	1060 uhy	2180 mmfd

Table I

Four coupling networks were constructed using the Table I data, and each was mounted on banana plugs so that the networks could be conveniently interchanged in the video circuit. Figure 2 shows the measured frequency response of the modified video stage using each of these networks.

Results

An example of one particular type of subject matter observed under four test conditions appears in Figure 3, where we have a series of photographs of images televised under the conditions which correspond to the curves given in Figure 2. When considering these photographs, it should be remembered that the eye is more critical of stationary scenes than of moving subject matter. The original photograph shown in Figure 3a was the standard of comparison. The appearance of Figures 3c and 3d is quite good considering the relatively narrow bandwidths employed for their transmission.

Tolerable Bandwidth Reductions

An inspection of this series of still photographs reveals that considerable sacrifice in bandwidth is permissible

(Continued on page 20)

you get **MORE PERFORMANCE**
for
LESS MONEY
with the **NEW Browning**
OSCILLOSYNCHROSCOPE



For only
\$485.00

this new five-inch Browning 'scope gives you the basic laboratory equipment for pulse work — in a single, compact unit with:

- Triggered sweep rate continuously variable from 1.0 to 25,000 microseconds per inch.
- Sawtooth sweep rate 10 cycles to 100 KC.
- Sweep calibration (triggered and sawtooth) in microseconds per screen division accurate to $\pm 10\%$.
- Vertical amplifier flat within 3 db. from 5 cycles to 5 megacycles.
- Sensitivity 0.075 volts RMS per inch.
- Horizontal amplifier d.c. to 500 KC, sensitivity 2 volts per inch.
- Self-calibrating on both X and Y axis.
- Readily portable . . . weighs but 50 pounds.

plus these ELECTRICAL and MECHANICAL features

- 5UP1 cathode-ray tube operates at accelerating potential of 2600 volts
- Sweep starting time is approximately 0.1 microsecond
- Sweep may be triggered or synchronized by positive or negative sine-wave or pulse signals of 0.5 volts (external) or 0.75 inches deflection (from vertical amplifier)
- Three-step attenuator — 100:1, 10:1, and 1:1, plus continuous adjustability over entire range
- Peak-to-peak vertical calibration voltages of 0-2-20-200 at accuracy of $\pm 10\%$
- Cathode connection, brought out to front panel, allows external blanking and marker connection
- All deflection plates are available for direct connection
- Steel cabinet finished in black wrinkle
- Steel panel finished in black leatherette
- Copper-plated steel chassis with lacquer finish
- Controls grouped by function for operating convenience
- Free-view screen has graduated X- and Y-axis scales
- Size: 10" wide, 14½" high, 16¾" deep
- Instrument draws 180 volt-amperes at 115 volts 60 cycles.

NET PRICE, F.O.B. Winchester, Mass. \$485.00

FREE BULLETIN gives further data on this new, low-cost, versatile oscillosynchroscope. Ask for data sheet ON-54E.

In Canada, address Measurement Engineering Ltd., Arnprior, Ontario

Export Sales
9 Rockefeller Plaza
Room 1422
New York 20



BROWNING
Laboratories, Inc.
Winchester, Mass.
ENGINEERED FOR ENGINEERS

Group Subscription Plan

You Save Half of the Subscription Price if
Four or More Orders, Including Your Own,
Are Properly Entered on This Form

To the Publishers of
TELEVISION ENGINEERING
52 Vanderbilt Avenue, New York 17, N. Y.

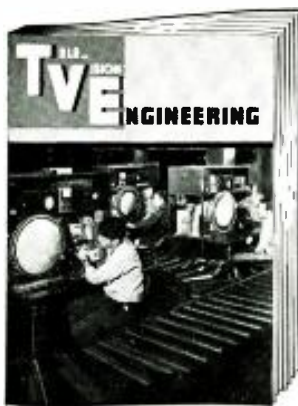

Please enter two-year subscriptions (24 issues) for each of the undersigned for which payment is enclosed at the rate of \$3.00 each. (This rate applies only on 4 or more subscriptions when occupations are given.) Regular cost is \$3.00 for one year.

Name

Address

City Zone State

Occupation Title

Department in which employed
 Operation Production Research

Employed by

Nature of Business

(State if TV Manufacturer, TV Broadcast Station, etc.)

Name

Address

City Zone State

Occupation Title

Department in which employed
 Operation Production Research

Employed by

Nature of Business

(State if TV Manufacturer, TV Broadcast Station, etc.)

Name

Address

City Zone State

Occupation Title

Department in which employed
 Operation Production Research

Employed by

Nature of Business

(State if TV Manufacturer, TV Broadcast Station, etc.)

Name

Address

City Zone State

Occupation Title

Department in which employed
 Operation Production Research

Employed by

Nature of Business

(State if TV Manufacturer, TV Broadcast Station, etc.)

Business or professional classifications are required to complete our records. Each subscriber should write one of the following classifications in space indicated. Use separate sheet of paper for additional names.

CHIEF ENGINEER ENGINEER EXECUTIVE
 PURCHASING AGENT DEPARTMENT MANAGER

State your classification if not listed.

This Group Sent in by—
 Name

Address

Video Bandwidth

(Continued from page 19)

without altering the general appearance of the image.

Upon observation of televised pictures, the relative effects of frequency and phase distortion can readily be distinguished, since frequency distortion produces symmetrical distortion, while phase distortion causes non-symmetrical distortion which results in a smearing of the reproduced picture elements. Thus, in Figures 3b, c and d, we note that the distortion present has been caused principally by poor frequency response. The value of $N = 0.5$ evidently provides a satisfactory compromise between good phase and frequency response for the compensated stage.

Convenience of Method

The experimental procedure outlined provides a convenient method of controlling the bandwidth of a video system so that test material can be observed and the transmission quality evaluated for a transmission band of given width and shape. Since it is difficult for the uninitiated observer to visualize the effect of frequency and phase distortion, it is felt that this technique will prove valuable for educational purposes in television courses. If a complete television system is not available, the technique of compensation described may be applied to the video circuit of a television receiver and the characteristics of program material may be studied under controlled bandwidth conditions.

Acknowledgment

The writers are grateful to the Engineering Experiment Station at Georgia Tech for its financial support of this project.

¹Staff of the Craft Laboratory, Harvard Univ., *Electronic Circuits and Tubes*, p. 253, McGraw-Hill, 1947.

²Biedford, A. V., and Fredendall, G. L., *Transient Response of Multistage Video-Frequency Amplifiers*, Proc. IRE: April 1939.

Next Month

THE CONCLUDING INSTALLMENTS of the C. F. Van Weiland paper on *RC Tuning Network Bandspreading and Scale Equalization* and the E. L. Hall paper on the *Coverage of Standard Frequency Station WVVH* will be presented in the October issue of TELEVISION ENGINEERING.

Instrument News

UHF Admittance Meter

A UHF ADMITTANCE METER, a null-type instrument, based on coaxial-line techniques has been produced, for making impedance measurements at the ultrahighs. It balances in the same manner as a bridge and indicates conductance and susceptance on direct-reading dials, the calibrations of which are independent of frequency. Null setting for both components are completely independent.

Can be used to measure conductances, and susceptances of either sign, from one millimho to 400 millimhos (1000 ohms to 2.5 ohms) over a frequency range from 70 to 1000 mc. Accuracy is said to be $\pm 5\%$. The admittance components can be converted to impedance, if desired, by using a Smith chart or Smith-chart slide rule.

Meter can also be used as a comparator to indicate equality of one admittance to another, or degree of departure of one from the other. As a direct-reading device, in addition, it can be used to determine the magnitude of the reflection coefficient of a coaxial system, or the magnitude of an unknown admittance, from ratios of output voltage read on a meter.

Terminals are G-R 874 coaxial connectors, a universal type, which requires no separate male and female elements.—Type 1602-A; General Radio Co., 275 Massachusetts Ave., Cambridge 39, Mass.

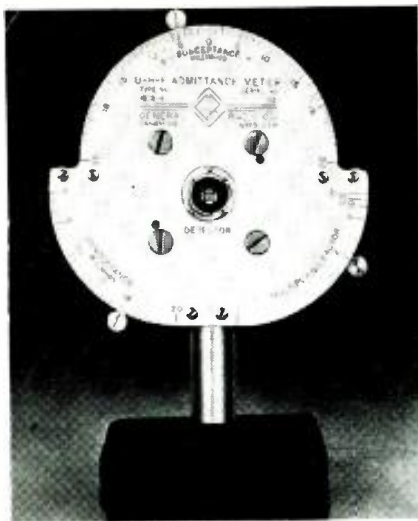

G-R uhf admittance meter

Capacity Bridge

A CAPACITY BRIDGE, which measures $3\frac{5}{8}''$ x $5\frac{1}{2}''$ x $2\frac{3}{8}''$, has been developed.

Tester features a patented circuit which allows for three capacity ranges: 20 to 500 mmfd, .005 to 2 mfd and 1 to 500 mfd.

Has an etched aluminum panel. Weighs $1\frac{3}{4}$ pounds.—Model 381; Simpson Electric Co., Chicago, Ill.

Oscillosynchroscope

AN OSCILLOSYNCHROSCOPE now available has a high-gain vertical amplifier with a response flat from 5 cps to 16 mc, extending beyond 30 mc, including the use of a .2 microsecond signal-delay line. Two completely separate sweep systems are said to permit accurate display of repetitive phenomena with recurrence rates as high as 10 mc, or transient and recurrent pulses as short as .05 microsecond.

Built-in trigger and delay generators are provided for synchroscopic applications such as those encountered in radar circuits.

Accurate time measurements may be made by use of 0.1, 1.0, 10, and 100 microsecond timing markers. Vertical signal amplitude measurements are likewise possible using a direct-reading deflection calibration system.

Consists of five separate chassis units assembled in a rack cabinet mounted on casters. A compartment is provided for permanent installation of an oscillo-record camera.—Model OJ-17; Browning Laboratories, Inc., Winchester, Mass.



Browning oscillosynchroscope

SWR Bridge

A STANDING-WAVE RATIO BRIDGE, $4\frac{1}{4}''$ x $2\frac{1}{4}''$ x $1\frac{5}{8}''$, has been designed.

Bridge is of resistance type and is intended for use with coaxial lines of either 52 or 75-ohm type. Will work with any low range dc instrument such as a 0-1 milliammeter.—No. 9067; James Millen Mfg. Co. Inc., 150 Exchange St., Malden, Mass.



Impedance Bridge

A UNIVERSAL IMPEDANCE bridge and bridge amplifier have been developed.

High accuracy is said to be insured by the use of wire-wound resistors adjusted to a precision of $\pm 0.05\%$ in the bridge arms. Directly-calibrated slidewire consisting of a 0.05% precision decade with a coaxially mounted single turn rheostat for interpolating within the decade steps is used as the main LRC dial.

Measurements can be made over 1 milliohm to 11 megohms; 1 mmfd to 1100 mfd; and 1 microhenry to 1100 henrys.

Storage factor of inductors (Q) 0.02 to 1000. Dissipation factor of capacitors (D) .001 to 1.0.

Included are the precision reference standards, 1000-cps tone generator, zero center suspension galvanometer with a deflection sensitivity of $\frac{1}{2}$ ua/mm, and replaceable flashlight cells to power the bridge.

The null amplifier is said to make possible a precision of balance of better than 0.1% on most measurements of capacitance and inductance. This amplifier may be placed in a compartment in the bridge and has a rectifier circuit which permits the bridge galvanometer or other suitable meter to be used as a visual null indicator.—Models 250-B and 805-B; Brown Electro-Measurement Corp., Dept. TE-1, 4635 S. E. Hawthorne Blvd., Portland 15, Oregon.



Brown impedance bridge

LF Q Indicator

A LOW-FREQUENCY Q INDICATOR has been designed to measure the Q factor of coils, and inductance, distributed capacity, impedances, and dielectric losses. The study of the magnetic properties of iron, including the stability of iron cores as a function of applied voltage, and iron losses as a function of the frequency, are additional uses for the indicator.

The Q factor can be read directly. The Q range is from 0.5 to 5. Frequency range is from 20 cycles to 50 kc.—No. 1030; Freed Transformer Co., Inc., 1718-36 Weirfield Street, Brooklyn 27, New York.

TV-FM Tuner

A VALUABLE-INDUCTIVE TUNER for use at TV and FM frequencies has been developed.

Has a fine tuning control which is concentric with the main tuner shaft and drives the main shaft through a speed reduction mechanism.

A 12AT7 serves as an *rf* amplifier, 6J6 as a Colpitts oscillator and 6AG5 as a mixer.

Tuner can be used for single output of the intercarrier type or separate outputs for separate sound and picture *if*.

Tuning is provided by series of copper plates, serving as a highly conductive shorted turn. *Lyt-L-Tuner*; S. W. A. Co., Inc., 4721 N. Kedzie Ave., Chicago 25, Ill.

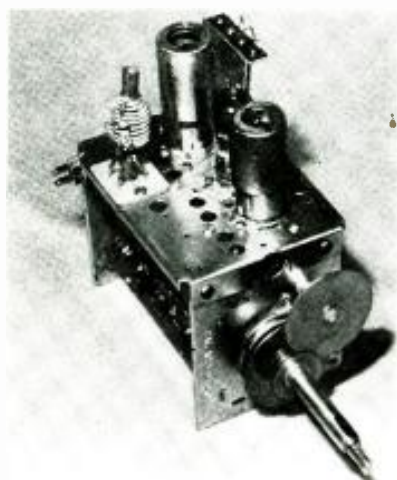

S.M.A. Tuner

Sealed Relays

HERMETICALLY SEALED relays featuring three stud mounting and solder lug terminals are now being produced. Enclosure will accommodate three ampere rated relays in contact combinations up to and including 1 pole-double throw. Measurements are 1 7/16" x 1 1/8" x 1 1/16" high. Part 8744-1; Advance Electric and Relay Co., 2435 North Naomi St., Burbank, Calif.



High Voltage TV Resistors

HIGH VOLTAGE RESISTORS have been designed to withstand the high *dc*, pulse and transient voltages encountered in TV power supplies.

Have a high stability carbon resistance coating applied on a steatite form. The coating is applied as a helix on the surface of the form to provide a long resistance path in a small space. Because of the long path length the voltage per unit length is said to be relatively low. Spacing between turns is said to be ample thus eliminating possibility of arcing or high voltage stress. Permanent connection is made to the ends of the resistor by means of a silver contact coating. Protective coating of electrical varnish applied to the surface of the resistor and cured at high temperature.

Tinned brass soldering terminals are fastened to the resistor ends by means of machine screws. Resistors can be furnished without terminals for mounting into special assemblies.

Offered in a range of resistance values covering the requirements of TV power supply circuits. The predominating resistance value used in present day circuits is 2 megohms. Furnished only to a tolerance of plus or minus 20%.

The temperature coefficient of resistance is approximately $-.05\%$ per degree C. The voltage coefficient of resistance is approximately $-.0001\%$ per volt. Types TBR and TFQ; Resistance Products Co., 714 Race St., Harrisburg, Penna.



Resistance Products TV Resistors

Selenium Rectifier

PLASTISEL SELENIUM RECTIFIERS with plates stacked and sealed in a plastic tube, are now available. Units resemble an electrolytic capacitor in shape and size, and are mounted by means of the conventional type pig-tail leads.

Delivery is now being made on the 40, 65, and 100-ma sizes, with others up to 500 ma available shortly. *TV Development Corp.*, 2505 Surf Ave., Brooklyn 24, N. Y.

Ceramic Flat-Plate Capacitors

CERAMIC FLAT-PLATE CAPACITORS are now being produced for miniature applications. Rated at 150 working volts *dc* and are flash tested at 300 volts. Capacity tolerances are maintained from 10° to 50° C. Units are insulated with a phenolic coating and have No. 26 tinned copper wire leads 1 3/4" minimum length. Size, 17/32" x 7/32" x 7/64".—*Min-Kaps*; Centralab.



Ernst Hardness Tester

A PORTABLE, DIRECT-READING *Ernst hardness tester* is now being distributed.

In use, hand-grips on the side of the instrument are pressed downwards to lower the indenter so that its point penetrates into the surface of the material being tested under the action of a carefully calibrated helical-spring exerting a constant load of 15 1/2 pounds. The movement of the indenter into the material is magnified about 3,000 times by the well-established method of displacing liquid from a container into a capillary tube. The tube is supported in a recess and encircles the scale so that the final position of the liquid indicates the hardness value directly.

Instrument can be used on curved as well as on flat surfaces, provided the radius of the curve is not less than 3/32". Overall dimensions: 3" high, 2 1/2" diameter.

Direct readings of hardness on visible scale to *Rockwell*, or if required, *Brinell*, *diamond pyramid*, or *tons tensile* Standard instruments high range are 25-65 Re. Medium range 35-75 Rockwell A or 100-100 Brinell. Low range 50-260 Brinell.

The load and application is very similar to *diamond pyramid* machines. For convenience of use, the scale has been graduated to *Brinell* conversion figures. Instruments, however, can be supplied to *diamond pyramid* or *Rockwell* scales, upon order. *Newage International Inc.*, 521 Fifth Ave., N. Y. (*Bulletin ET-39* available).

Wire Stripper

A WIRE STRIPPER equipped with vacuum base, using a principle of frictionally generated heat to melt enamel and Formex type insulations, is now available. Selection from different grades of stripping wheels is said to permit clean removal of all kinds of insulations without damage to the wire.

Model shown will strip wires, gauges 18 through 25, including Litz wire up to 50/44. Stripping wheels may be resurfaced or dressed as they wear.

Stripper shown is 10" wide, 15" deep, and weighs 38 pounds, complete with motor and 6' lead. *Rush Wire Stripper Div.*, *The Eraser Co., Inc.*, Syracuse 2, N. Y.

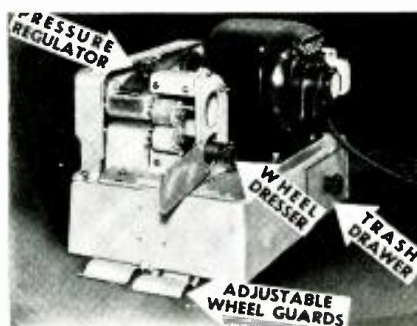

Field Tested Antenna Installation Information



Over 35,000 words of vital data . . . With over 130 photos and drawings . . . Detailed illustration and subject index for rapid reference.

VV "The best book on the market at this time dealing with the problem of television antennas and antenna installation . . . If more Service Men would read this book, it would help them considerably in making better installations and providing better television reception for their customers."—*M. J. Shopp, President, Jerrold Electronics Corp.*

VV "Will recommend it to all the Service Men and technical people I meet."—*Charles Cahn, Field Service Engineer, Bendix Radio.*

VV "Well organized and illustrated, very complete and up-to-date, carefully detailed. It will definitely improve the ability of the man who studies it and therefore is mighty useful to a firm like ours."—*Hamilton Hoge, President, United States Television Mfg. Corp.*

VV "Will certainly fill a long-felt need for some practical information . . . sincerest congratulations."—*George P. Adair, Former Chief Engineer, FCC, and now Consultant in Washington, D. C.*

VV "A thorough-going compendium of the installing art . . . Going to recommend it highly to our Service Control Department and our service organizations."—*Ernest A. Marx, General Manager, Television Receiver Sales Div., Allen B. DuMont Laboratories, Inc.*

VV "Informative and extremely well written."—*R. Morris Pierce, President and General Manager, WDOK.*

VV "Most complete analysis of the antenna installation problem I have seen as yet."—*A. T. Alexander, Service Manager, Motorola, Inc.*

VV "First really good publication I have found on the subject."—*E. K. Jett, Former FCC Commissioner and now Vice-President, WMAR.*

VV "I have just finished looking through your book . . . and find it very interesting and informative."—*A. James Ebel, Director of Engineering, Peoria Broadcasting Co.*

VV "The Radio-Television Division of the Massachusetts Trades Shops Schools has just decided to incorporate the book within its curriculum. . . . The book will be issued to all future television starting classes at the school."—*Donald M. Bearse, Purchasing Agent, Massachusetts Trades Shops School, Boston.*

TV-FM Antenna Installation

by IRA KAMEN

TV Antenna Consultant

and LEWIS WINNER

Editorial Director,

Bryan Davis Pub. Co., Inc.;

Editor, SERVICE and TELEVISION ENGINEERING

The *only practical book* on the key link to TV and FM reception . . . based entirely on actual, roof-top experiences in the most active TV and FM areas in the country.

The *first book* in which you'll find complete design and installation information on every type of TV and FM receiving antenna and accessory.

10 Fact-Packed Chapters on . . .

Installation Tools	Fringe Reception
Antenna Installation Procedures	Master Antenna Systems
Securing 12-Channel Coverage	FM Antennas
HF Antenna Installations	Installation Business Practices
TV Interference	Tricks of the Trade

At your Jobber or Order Direct . . . \$2.00 Postpaid

BRYAN DAVIS PUBLISHING CO., INC., Book Dept.
52 Vanderbilt Avenue, New York 17, N. Y.

Send me a copy of TV . . . FM Antenna Installation, postpaid, for which I am enclosing \$2.00.

(Please print)

NAME

ADDRESS

CITY AND STATE

Before Any Other Consideration

Integrity of Circulation

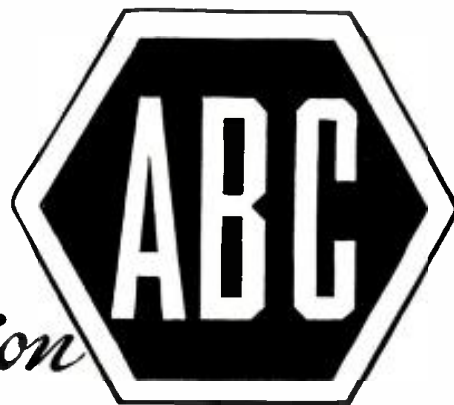

OF THE several factors that enter into the use of published media, the distribution of the advertisers' sales messages, as governed by the selection of media, can of itself decide the success or failure of the advertising investment. That is why integrity of circulation is the first consideration with experienced space buyers.

The emblem shown above stands for the FACTS that make it possible for advertisers to select the right media and to know what they get for their money when they invest in publication advertising. It is the emblem of membership in the Audit Bureau of Circulations, a cooperative and nonprofit association of 3300 advertisers, agencies and publishers.

Working together, these buyers and sellers of advertising have established standards for circulation

values and a definition for paid circulation, just as there are standards of weight and measure for purchasing agents to use in selecting merchandise and equipment. In other words, A.B.C. is a bureau of standards for the advertising and publishing industry.

A.B.C. maintains a staff of specially trained auditors who make annual audits of the circulations of the publisher members. Information thus obtained is issued in A.B.C. reports for use in buying and selling space. All advertising in printed media should be bought on the basis of facts in these reports.

This business paper is a member of the Audit Bureau of Circulations because we want our advertisers to know what they get for their money when they advertise in these pages. Our A.B.C. report gives the facts. Ask for a copy and then study it.

SOME OF THE AUDITED INFORMATION IN A.B.C. BUSINESS PAPER REPORTS

SEND THE RIGHT MESSAGE TO THE RIGHT PEOPLE

Paid subscriptions and renewals, as defined by A.B.C. standards, indicate a reader audience that has responded to a publication's editorial appeal. With the interests of readers thus identified, it becomes possible to reach specialized groups effectively with specialized advertising appeals.

- How much paid circulation.
- How much unpaid circulation.
- Prices paid by subscribers.
- How the circulation was obtained.
- Whether or not premiums were used as circulation inducements.
- Where the circulation goes.
- A breakdown of subscribers by occupation or business.
- How many subscribers renewed.
- How many are in arrears.

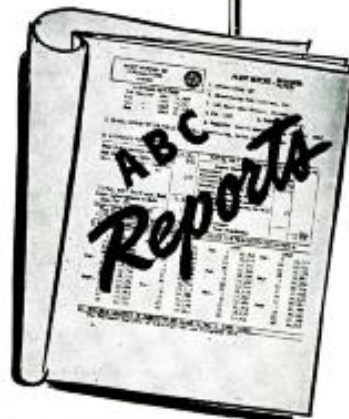

TELEVISION ENGINEERING

A.B.C. REPORTS — FACTS AS THE BASIC MEASURE OF ADVERTISING VALUE

Picture-Tube Production

In-line oven unit system developed for picture-tube production. A rt bombarder and filament activating machine is at the left of the dolly line.

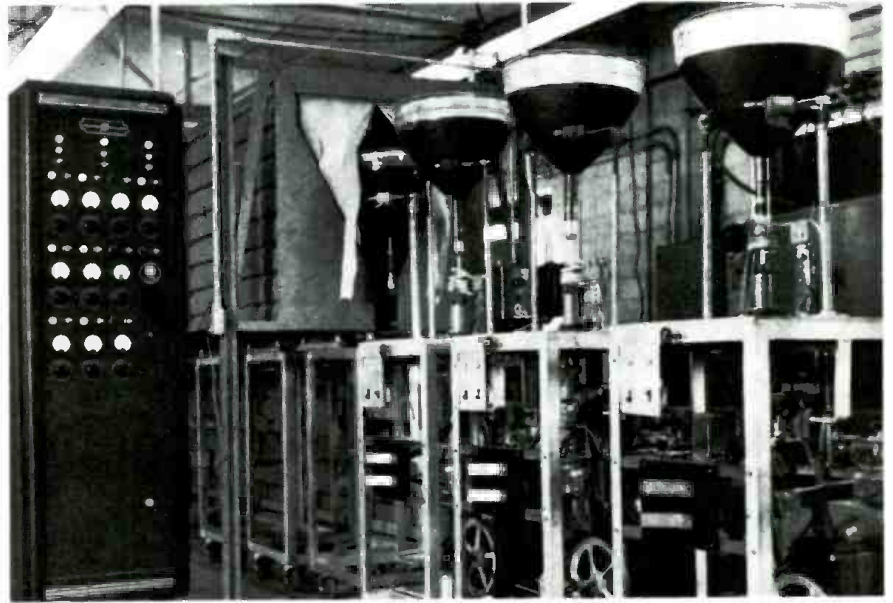

Picture-tube machine shop, equipped to produce all parts needed for any of the machines used in TV tube production, as well as components for the tubes.

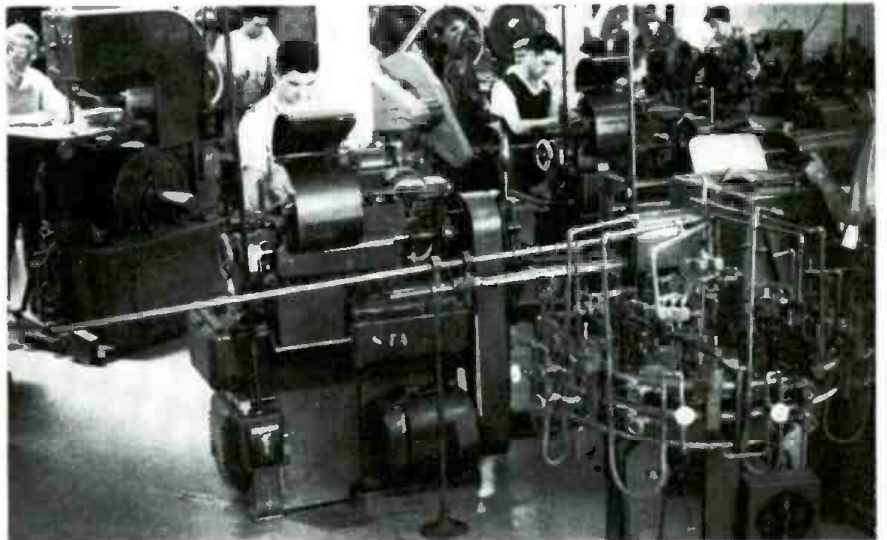

Operator re-necking a picture tube on a glass lathe. This step is necessary when a flaw is found in the finished tube and the unit is rejected by inspection. Operator then receives the tube for removal of the old neck, and re-necking of the blank for future use follows.

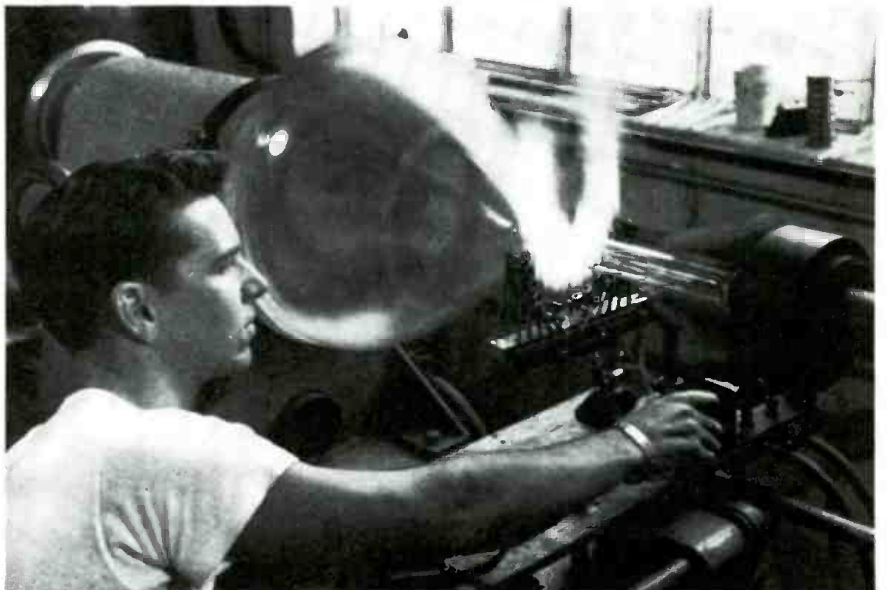

[All photos courtesy Haydu Brothers]

AMPERITE

Studio Microphones
at P.A. Prices

Ideal for
BROADCASTING
RECORDING
PUBLIC ADDRESS

"The ultimate in microphone quality," says Evon Rushing, sound engineer of the Hotel New Yorker.

- Shout right into the new Amperite Microphone—or stand 2 feet away—reproduction is always perfect.
- Not affected by any climatic conditions.
- Guaranteed to withstand severe "knocking around."



Models
RBLG—200 ohms
RBHG—Hi-imp.
List \$42.00



"Kontak" Mikes
Model SKH, list \$12.00
Model KKH, list \$18.00

Special Offer: Write for Special Introductory Offer, and 4-page illustrated folder.

AMPERITE Company, Inc.

561 BROADWAY • NEW YORK 12, N. Y.

Canada: Atlas Radio Corp., Ltd., 560 King St. W., Toronto

DON'T MISS
THE LYT-L-TUNER
BOOTH 33-34
N.E.C. EXHIBIT
SEPT. 25-26-27
Edgewater Beach Hotel
CHICAGO

FOR YOUR TV PRODUCTS
SELL THE ENTIRE TV MARKET

in
TELEVISION ENGINEERING

Complete Market Coverage
Maximum Reader Interest
Absolute Editorial Focus

The Orthogam

(Continued from page 13)

grid of V_3 to insure that the blacks in the picture always occur at the same point on the tube characteristic. The heart of the amplifier is the third tube, V_3 , a 6AH6 operated as a non-linear amplifier. This stage has a high degree of degeneration in its cathode circuit. Germanium crystals are shunted across this cathode impedance and their performance determines the non-linear amplifying characteristic of the tube. The polarity of the video voltage on the grid of this stage is such as to have the white portions of the picture signal in the positive or upward direction, and the germanium crystals are polarized in such a way that increasing voltage at the cathode of V_3 will cause them to conduct. The amplifying characteristic of the stage is then such that for black or near black there is a high degree of degeneration in the amplifier stage, and as the signal approaches white amplitude the amount of degeneration is reduced by the shunting action of the crystals which conduct, thereby increasing the stage gain. The potential at which the germanium crystals reduce the degeneration of the stage depends upon the setting of the potentiometers, P_2 and P_3 , which control the voltages supplied to the crystals.

Following the non-linear amplifier stage V_3 , is a gain stage, V_4 , and two output stages, V_5 and V_6 , which are all straightforward video amplifiers. The potentiometer, P_5 , in the cathode circuit of V_4 is used to control the overall gain of that stage. The two output stages, V_5 and V_6 , are each driven from V_4 , thus providing two outputs, a line and a monitor, whose respective gains can be controlled by potentiometers P_6 and P_7 in their cathode circuits. They are capacitively connected to the load.

In the normal operation of the orthogam amplifier, the incoming video signal level should first be determined and the input potentiometer, P_1 , adjusted so that under normal conditions of operation the peak-to-peak voltage on the grid of V_1 will be approximately .5 volt. When the potentiometers, P_2 and P_3 , are turned to their most counterclockwise position, the crystal diodes will be biased open and the amplifier will have a linear characteristic. As the potentiometers P_2 and P_3 are turned clockwise, the crystal diodes will become conductive on white peaks and thereby provide increased amplification to the white end of the video signal because the degeneration in the third stage has been reduced with a resultant increase in stage gain.

Two shunt crystal circuits are employed in this amplifier, one consisting of two 1N54 crystals and a variable re-

sistance P_4 , the other consisting of a single 1N54 having a fixed resistance of 220 ohms in series with it. The potentiometer, P_2 , controls the *dc* potential applied to the two series crystals and determines one peak point in the overall amplifier characteristic. Two crystals in series smooth out some of the abrupt break in the resultant non-linear amplification characteristic of the stage, and the series resistance, P_4 , limits the stage gain in the stretched condition. Normally P_4 is turned to its maximum clockwise position, where it is out of the circuit permitting maximum stage gain. In some cases, it may be desirable to increase the separation in the extreme white portion of the picture signal, and to accomplish this a second diode circuit has been included. The conduction point of this circuit is controlled by the *dc* potential applied to the second crystal circuit via potentiometer, P_8 . The action of this circuit is to produce a second break point in the overall characteristic in the region of the extreme white portion of the signal. In actual practice the two controls, P_7 and P_8 , have to be adjusted simultaneously as there is some interaction between the two. A variety of transfer characteristics can be obtained by careful adjustment of the potentiometers P_2 , P_3 and P_4 . Two shunt crystal circuits afford a fairly good



HOTEL STRAND

ATLANTIC CITY'S
IDEAL CONVENTION HOTEL

Exceptional Convention Facilities adaptable to small, medium or large groups. Ample Meeting, Banquet and Exhibition Rooms. Wonderful location on Boardwalk opposite Steel Pier, the center of Atlantic City. Write Convention Manager TODAY.

The Strand features Spacious Colorful Lounges—Open and Inclosed Solaria—Salt Water Baths in Rooms—Garage on premises. Courteous Personnel.

When in Atlantic City visit
FAMOUS FIESTA LOUNGE
"Food for Epicures"
Exclusive Penna. Avenue and Boardwalk

THE ONLY DIRECT READING LOW FREQUENCY "Q" INDICATOR



**FREED
NO.
1030**

This instrument is designed specifically to measure the "Q" factor of coils. In addition, the unit can be used to measure inductance, distributed capacity, impedances, and dielectric losses. The study of the magnetic properties of iron, including the stability of iron cores in function of applied voltages, and iron losses as a function of the frequency, are additional uses for the Freed "Q" indicator.

The main and essential feature of this instrument is that the "Q" factor is read directly without any complicated computations. The possibility of measuring "Q" through the whole audio and super-audio frequency range is provided. "Q" range is from .5 to 500 over the frequency range from 50 to 50,000 cycles. Accuracy of "Q" measurement is approximately 5% for frequencies up to 50,000 cycles. Oscillator frequency range is continuously variable from 20 to 200,000 cycles in four ranges.

SEND FOR THE NEW FREED CATALOG

FREED TRANSFORMER CO., INC.
Dept. SL, 1718 WEIRFIELD ST., BROOKLYN
(RIDGWOOD) 27, NEW YORK

BIRTCHEr STAINLESS STEEL - LOCKING TYPE TUBE CLAMPS

Stainless
Steel

Corrosion
Proof



83 VARIATIONS

Where vibration is a problem, Birtcher Locking TUBE CLAMPS offer a foolproof, practical solution. Recommended for all types of tubes and similar plug-in components.

More than three million of these clamps in use.

FREE CATALOG

Send for samples of Birtcher stainless steel tube clamps and our standard catalog listing tube base types, recommended clamp designs, and price list.

THE BIRTCHEr CORPORATION
5087 HUNTINGTON DR. LOS ANGELES 32

power function characteristic for this stage of the amplifier.

There are five separate positions on the characteristic selector knob, any one of which may be chosen by the operator. The first, or number 1 position, simply connects the input to the output completely removing the amplifier from the circuit. The variable controls, P_1 , P_2 and P_3 , are associated with position 2, and may be adjusted to suit the individual's desires. Fixed degrees of compensation are provided in positions 3, 4 and 5. These characteristics are entirely arbitrary and may be changed by making appropriate modifications within the units.

An emergency switch is provided, whereby the shunting diode crystals may be made inoperative and the non-linear action of the amplifier thereby removed without the necessity of turning the characteristic selector knob back to position 1. It is merely a convenient way of removing the non-linear amplifier characteristic from the circuit in the case of trouble. This switch should be turned to the *on* position, when the amplifier is in use. When using this emergency ratchet, a readjustment of the linear gain control, P_4 , will be required to maintain the overall gain of the linear amplifier so produced. If desired, this switch may be replaced by a potentiometer, thus giving a continuously varying amount of control to the non-linear amplifier for various stage characteristics determined by the potentiometers P_2 , P_3 and P_4 . This control may be remotely located with respect to the amplifier.

The unit is normally used in conjunction with a standard studio type iconoscope film chain and should be connected directly in the output of the camera control unit. By careful manipulation of the controls a substantial improvement in the overall transfer characteristic of the television system can be effected. This will be evidenced by a reduction in the chalkiness in the faces and increased separation between the white and near-white portions of the images reproduced. The average brightness of the picture will be reduced somewhat inasmuch as the *ac* axis has been pushed toward the blacks. The result is a more natural and pleasing reproduction.

Credits

This development is the result of the combined efforts of several. Many grateful thanks, too, to Pierre Boucheron and C. L. Townsend of NBC, and Otto Schade of RCA Victor Division for their helpful criticisms and suggestions

©RCA.

EMSCO ENGINEERED RADIO TOWERS

FOR AM, FM, VHF,
UHF, MICROWAVE,
TELEVISION AND RADAR

EMSCO Towers are available for all types of broadcast and communication service. Backed by years of fabricating experience, EMSco towers are engineered for safety, performance and economy. Bolted construction and hot dip galvanizing insure long life, low maintenance cost and maximum electrical conductivity. Self-supporting triangular and square towers and guyed triangular towers are available in heights up to 1,000 feet with wind loadings up to 60 lbs RMA design.

Shown here is an EMSco Type 2RT 120-foot 40" RMA design tower installed for Southwestern Bell Telephone Co. in Dallas, Texas. →

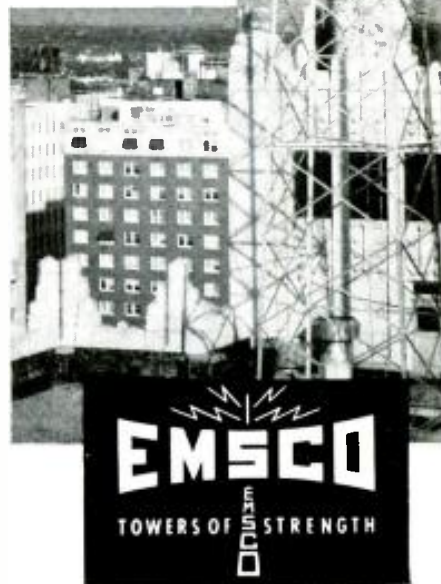

EMSCO DERRICK & EQUIPMENT COMPANY
LOS ANGELES, CALIFORNIA
Houston, Tex.: • Garland, Texas

It's EASY to install "Payroll Savings"

... and 20,000 companies' experience proves it pays!



In case you're skeptical as to how many of your employees would like to have Payroll Savings, canvass your plant—and be prepared for a surprise. (Remember that pay-check withholdings for Bonds are *not* a "deduction"—the employee takes home his Bonds with his pay.) One leading manufacturer, who had professed little faith in the Plan, found his eyes opened when he asked the people in his plant whether they would like to obtain Bonds in this way. Within only six months after he installed the

Plan, half his employees signed up. A prominent aircraft manufacturer, whose company had used the Plan for some time, was not aware of its potentialities until his personal sponsorship increased participation by 500% among his company's employees.

THE BENEFITS ARE BIG— FOR EVERYONE

The individual employees gain security—they know that the Bonds they hold will return \$4 for every \$3 at maturity. The company gains from



If you've put off installing the Payroll Savings Plan in your company because you feel it would be "a lot of work," then this advertisement is certainly for you! Because it's really very simple to give your employees the advantages of investing in U. S. Savings Bonds the easy, automatic "Payroll" way.

HERE'S ALL YOU NEED TO DO

Appoint one of your top executives as Savings Bond Officer. Tell him to get in touch with your State Director, Savings Bonds Division, U. S. Treasury Department. Here's what happens . . .

The State Director will provide application cards for your employees to sign—plus as much promotional material and personal help as necessary to get the Plan rolling in your company.

Those employees who want Savings Bonds indicate on the applications: how much to save from their pay; what denomination of Bonds they want; and the inscription information to appear on the Bonds.

Your payroll department arranges to withhold the specified amounts, arranges to get the Bonds, and delivers them to the employees with their pay.

The Bonds may be obtained from almost any local bank or from the Federal Reserve Bank or may be issued by the company itself upon proper certification by the Federal Reserve Bank or Branch in the company's District.

THAT'S ALL THERE IS TO IT!

the resultant increased stability and efficiency of its workers. The whole nation gains because Bond sales help stabilize our economy by spreading the national debt and by creating a huge backlog of purchasing power to boost business in the years ahead.

Is it *good policy* to deprive your company of Payroll Savings—even one more pay day? Better at least have a talk with your U. S. Savings Bonds State Director, get the answers to your questions, and *know for sure*.

The Treasury Department acknowledges with appreciation the publication of this message by



TELEVISION ENGINEERING

This is an official U. S. Treasury advertisement prepared under the auspices of the Treasury Department and The Advertising Council.

Personals

Mark Glaser, vice president in charge of engineering of DeWald Radio and Television Corp., 35-15 37th Ave., Long Island City, New York, recently celebrated his twentieth year of uninterrupted association with the company. During this period of time, Glaser has designed over a thousand different types of radio sets and a number of TV receivers.



M. Glaser

Anthony J. Albano, chief engineer of the Tel-O-Tube Corporation of America, East Paterson, New Jersey, has been elected secretary of the corporation.



A. J. Albano

Warren Frebel has joined Majestic Radio & Television, Inc., 70 Washington St., Brooklyn, N. Y., as purchasing agent. Frebel was formerly purchasing director at Meck Industries, Inc.



W. Frebel

Philip Barnes has been named general sales manager of the Weston Electrical Instrument Corporation, Newark, N. J.



Philip Barnes

Sidney F. Studig, WBZ-TV technical supervisor, has been recalled to active Navy duty as a communications technician. Transmitter supervisor *Fred Osgood* has been named to the vacated video spot. Replacing Osgood at the WBZ transmitter post will be *Ellis H. Crossman*, for 20 years on the technical staff at WBZ's sister station in Springfield, WBZA.

Fred Kooiman, associated with Thomas Electronics as general sales manager, died recently.

MEASUREMENTS CORPORATION MODEL 80

STANDARD SIGNAL GENERATOR



2 to 400 MEGACYCLES

MANUFACTURERS OF
Standard Signal Generators
Pulse Generators
FM Signal Generators
Square Wave Generators
Vacuum Tube Voltmeters
UHF Radio Noise & Field
Strength Meters
Capacity Bridges
Megohm Meters
Phase Sequence Indicators
Television and FM Test
Equipment

MODULATION: Amplitude modulation is continuously variable from 0 to 30%, indicated by a meter on the panel. An internal 400 or 1000 cycle audio oscillator is provided. Modulation may also be applied from an external source. Pulse modulation may be applied to the oscillator from an external source through a special connector. Pulses of 1 microsecond can be obtained at higher carrier frequencies.

FREQUENCY ACCURACY $\pm .5\%$

OUTPUT VOLTAGE
0.1 to 100,000
microvolts

OUTPUT IMPEDANCE
50 ohms

MEASUREMENTS CORPORATION

BOONTON NEW JERSEY

DON'T MISS THE LYT-L-TUNER

BOOTH 33-34

N.E.C. EXHIBIT

SEPT. 25-26-27

Edgewater Beach Hotel
CHICAGO

TELEVISION ENGINEERING

The ONLY trade publication which directs its ENTIRE editorial content to executives and engineers who design, manufacture, operate and maintain television receiving and transmitting equipment — both commercial and governmental.

Reserve Space Now!

IMPORTANT personal and professional OPPORTUNITIES for experienced ELECTRONICS ENGINEERS

A broad program of research, design and development in new electronic fields with vast commercial applications by the manufacturer of Freed-Eisemann radio-phonographs and television receivers provides an opportunity for gaining valuable experience in new electronic concepts and techniques under the direction of scientists of international repute. Adequate facilities, pleasant conditions and attractive salaries make this an opportunity for personal as well as professional advancement. Many openings for experienced electronic engineers . . . including:

Project Physicist for fundamental electron tube research. Ph.D. or M.S. degree and extensive technical experience in the field of photo-electric, secondary emission, solid state, electron and physical optics.
Senior Electronics Engineer and Juniors: B.S. or M.S. degree, three to five years experience in television, radar, and display circuits.

Project Engineer: Capable of designing low-power transmitters and receivers, AM, FM and UHF.

Furnish complete resume of education and experience, salary required to Director of Research.

FREED RADIO CORPORATION
200 HUDSON ST. - NEW YORK 13, N. Y.

Always IN LINE



GUARDIAN CENTERING MAGNETS and FOCUS COILS Insure Better Positioning of the Pattern in Popular TV Sets . . .

GUARDIAN CENTERING MAGNETS

The Guardian Centering Magnet compensates magnetically for any misalignment of the electronic beam of the focus coil assembly. Eliminates manual adjustment of the raster.



GUARDIAN FOCUS COILS

Over a million Focus Coils have rolled off Guardian's production lines into TV sets of leading manufacturers. With more than 75 types established as *Guardian standard*, speedy delivery to meet today's replacement needs is a matter of routine. Write.



GUARDIAN  ELECTRIC
1615K W. WALNUT STREET CHICAGO 12, ILLINOIS

A COMPLETE LINE OF RELAYS SERVING AMERICAN INDUSTRY

WHEN YOU CHANGE YOUR ADDRESS

Be sure to notify the
Subscription Department of



52 Vanderbilt Avenue
New York 17, N. Y.

The Post Office Department does not forward magazines unless you pay additional postage, and we cannot duplicate copies mailed to the old address. We ask your cooperation.

Personals

WE'VE RECEIVED SOME INTERESTING biographical notes from Arthur E. Ridley, which reveal that his dot and dash experiences began in '01 as a ham. In '11 he received a *certificate of skill* and shortly thereafter joined the old Marconi Co., on the S.S. Millinocket (KNM) plying between Stockton, Maine, N. Y., and Boston, carrying newsprint. In the first few months he reports, he had enough experiences to satisfy almost anyone: Six fires aboard, some at sea, and with two casualties to the crew. "No one knew what to expect next," he said. "Finally one of the junior engineers was found to be a pyromaniac." During this time his ship was rammed, during a thick fog in Vineyard Sound, by the S.S. Persian and split below the waterline, just a foot or so aft of the engine-room bulkhead. Describing this hair-raising incident, Arthur related that he sent an SOS but recalled it when it was found possible to keep afloat and moving, although the hold was rapidly filling. By keeping as close to the shore as possible, the ship was finally brought to Vineyard Haven, with 24 feet of water in the hold. Arthur said that he had to keep in constant contact with the authorities during the wait for wrecking tugs. AR cites another incident, of

VWOA News

which he is quite proud, involving Brig. Gen. David Sarnoff, who as an inspector, came aboard ship in N. Y. to look over the equipment under his care. AR says that he hopes . . . "some day if I am lucky, to shake his hand and say *hello* once more." In '17 AR joined Western Union in Boston and he is still with the company. He and his wife are hams (6 meters), his call letters being WIDJ, and his wife's W101R. . . . F. D. Pizzuti, who has been teaching radio communications at Delehanty's Institute for the past two years, has also been busy writing TV articles. . . . In our ranks now is Nicholas Esposito, Flushing, N. Y., who began to pound brass January, 1920, aboard such ships as the SS East Side, Juneau and Sunbeam. The story of his last trip aboard the East Side which was replete with thrills, will be told soon in these columns. Watch for it! . . . E. N. Pickerrill sends his best to all from San Francisco where he is spending a few months since retiring from RCAC earlier this year. . . . H. B. Koch is spending his vacation in his home town, Joplin, Missouri. . . . Doc De Forest's book *Father of Radio* will be offered to the public soon. VWOA members may ob-

tain a copy at a special reduced price. Write to ye secretary for details. Incidentally your copy will be autographed by Doc. . . . H. D. Burman is now holding down the relief watch at WSV which, by the way, is the RMCA coastal station at Savannah, Georgia. . . . Jim Burns (W3KOU) has moved into his new home in Baltimore, Md. He is back on the air with 2, 40 and 10-meter rigs. . . . Interesting note from J. F. De Bardeleben, FCC engineer in charge at Muskogee, Oklahoma, reveals that for 3 years he was in the ship operating game, mostly on the Bessemer City of the Isthmian SS Lines. For ten years he was with KPRC, Houston, Texas, in engineering departments and all phases of the game. He even tried a year at radio service shop and sales work. Returned to *bc* work and then to the FCC in 1940 and has been with the Government ever since. Spent two years on loan to the State department on foreign duty, engaged in counter espionage work of a secret nature. In Kingsville, Texas, he served as assistant supervisor of the monitoring station for 2 years. Built new monitoring stations at Broken Arrow and Muskogee, Okla. The Muskogee station is located on a ranch 20 miles from town where there is plenty of space for antennas and such things. Holds ham call, W5PK.

Industry Literature

Anchor Plastic Co., Inc., 533 Canal Street, New York 13, N. Y., have released an 8-page brochure which explains many forms of plastic extrusions. Photographs and sketches of components fabricated for a wide variety of products are offered.

The *RCA Tube Department* has brought out a revised 24-page edition of the reference booklet *RCA Receiving Tubes for AM, FM, and Television Broadcast*.

Booklet (Form 1275-E) can be obtained from RCA tube distributors, or by sending 10 cents to Commercial Engineering, RCA Tube Department, Harrison, N. J.

DON'T MISS

THE LYT-L-TUNER

BOOTH 33-34

N.E.C. EXHIBIT

SEPT. 25-26-27

Edgewater Beach Hotel

CHICAGO

ADVERTISERS IN THIS ISSUE

TELEVISION ENGINEERING SEPTEMBER, 1950

AMPERITE CO.	26
Agency: H. J. Gold Co.	
AUDIT BUREAU OF CIRCULATIONS	24
BIRTCHEER CORPORATION	27
Agency: Crinsley & Jeffries, Inc.	
BROWNING LABORATORIES, INC.	19
Agency: Engineered Advertising	
CARTER MOTOR CO.	31
Agency: Robert Peterson Adv. Agency	
ALLEN B. DuMONT LABORATORIES, INC.	1
Agency: Austin C. Lescarboura & Staff	
EMSCO DERRICK & EQUIPMENT CO.	27
Agency: The McCarty Co.	
FREED RADIO CORP.	29
FREED TRANSFORMER CO., INC.	27
Agency: Franklin Adv. Service	
GENERAL RADIO COMPANY	Inside Back Cover
Agency: The Barba Press	
GUARDIAN ELECTRIC	30
Agency: Kennedy & Co.	
MEASUREMENTS CORPORATION	29
Agency: Frederick Smith	
RADIO CORPORATION OF AMERICA	Back Cover
Agency: J. Walter Thompson Co.	
SPRAGUE ELECTRIC COMPANY	4
Agency: The Harry P. Bridge Co.	
HOTEL STRAND	26
SYLVANIA ELECTRIC PRODUCTS, INC.	3
Agency: Cecil & Presbrey, Inc.	
THOMAS ELECTRONICS, INC.	Inside Front Cover
Agency: Conti Advertising Agency, Inc.	
U. S. TREASURY DEPARTMENT	28

Briefly Speaking . . .

THE NINE TO TEN-MILLION TV receivers which are expected to be in use before the year is out, were cited as the highest per-person distribution in the world in a recent talk by Doc Baker, G. E. vice prexy. This dominant expansion, revealed Doc, provides quite a contrast with the TV sets available elsewhere throughout the world, such as in the Soviet Union, where an estimated 50,000 are in use, or one for every 4,228 people. . . . Large-type picture tubes, 14 inches and over, now constitute more than 89% of the sales to receiver manufacturers according to RTMA. The tubes which were popular last year, the 12 to 13.9-inch types, amounted to only 10% of the sales up to June of this year. . . . The famous trade-marks of RCA: *Inconoscope*, *Kinescope* and *Acorn*, have been voluntarily surrendered to the public domain. . . . The winter meeting of the AIEE will be held in New York, January 22-26, at the Hotel Statler. . . . A professorship honoring Charles E. Wilson, president of G. E., has been established at the Graduate School of Business Administration—George F. Baker Foundation of Harvard University. The professorship was set up by the board of directors of G. E. in recognition of Mr. Wilson's 50 years of continuous service to the company. . . . Haydu Brothers, Plainfield, New Jersey, have expanded their plant facilities for the production of electron guns of both the straight and tilt-gun types. . . . Westinghouse Electric Corp. will soon build a new TV receiver manufacturing plant at Metuchen, New Jersey, on a ten-acre site, with 40,000 square feet of floor space. About 3,000 people are expected to be employed at the new plant. . . . Irvin L. Porter has been elected a director of the Kellogg Switchboard and Supply Co., 6650 S. Cicero Ave., Chicago, succeeding John Jay Bryant, Jr., who died recently. . . . Charles B. Denton is now advertising manager of the Weston Electrical Instrument Corp., Newark, N. J. . . . Tetrad Company, Inc., 4921 Exposition Blvd., Los Angeles 16, Calif., has been formed to manufacture miniature solenoid coils, as well as special items for TV including horizontal-flyback output transformers, deflection yokes, focus coils, etc. Leonard Juniper is prexy of the new company; George Clark, sales engineer and Joe McGarvey, plant manager. . . . The Andrew Corp., 363 E. 75th St., Chicago 19, are scheduled to build a special 3-radiator TV antenna for WJZ-TV to be mounted atop the Empire State Building, N. Y. C. Antenna will accommodate 30-kw peak video and 20-kw audio.



HOW LEADING NETWORKS USE Carter CONVERTERS

Photo above shows NBC's Tommy Bartlett and Universal Recording Company engineers making transcriptions from STORAGE BATTERY POWER by means of Carter Frequency Controlled Converter.

Wherever 115v. line voltage is not available, or hard to get, Carter Converters supply dependable AC power to make on location recordings, Operates from storage batteries. . . . Used by leading networks, broadcast stations, and program producers.

Recommended by Brush and Magnecord

One model operates both Brush and Magnecord equipment. Delivers clean 60 cycle AC power. Requires no filtering. Frequency control feature compensates for 10% input voltage variation. Available for 6, 12, 24, 28, 32, 64, and 115v. DC input voltage. Size 8 1/2" x 5 1/2" x 7 1/2" high. Weight only 15 3/4 lbs. Performance Guaranteed!



MAIL COUPON FOR FREE CATALOG

New Converter catalog illustrates entire line of Carter Rotary Converters for recording, TV, sound projection and transcription players, SELECTOR CHART included tells model to suit your purpose. Mail Coupon now for your copy and name of nearest Carter distributor.



Carter MOTOR CO.

2656 N. Maplewood Ave., Chicago 47

Carter Motor Co.
2656 N. Maplewood Ave.
Chicago 47, Ill.

Please send catalog #349 with information on Frequency Control Converters, and name of nearest distributor.

Name

Station or
Company

Address

Latest WELLS Tube Price List

Many Types Are Now Scarce At These Low Prices. Check your requirements at once for your own protection. All tubes are standard

brand, new in original cartons, and guaranteed by Wells. Order directly from this ad or through your local Parts Jobber.

TYPE.	PRICE EA.	TYPE.	PRICE EA.	TYPE.	PRICE EA.	TYPE.	PRICE EA.	TYPE.	PRICE EA.	TYPE.	PRICE EA.
0A4G	.95	5AP1	3.75	7B4	.55	RK60/1641	.65	HY615	.35	866A	1.30
EL-C1A	3.95	EL-CSB	4.25	7B8	.60	VT62 BRITISH	1.00	WL632A	8.75	869	19.75
1A3	.60	5BP1	2.45	7C4/1203A	.35	HY65	3.25	700	17.95	869B	27.25
1A5GT	.65	5BP4	3.95	7C5	.60	66B4	.90	700B	17.95	872A	2.45
C1B/3C31	3.75	5CP1	2.45	7C7	.60	VT67/30	.58	700C	17.95	874	.90
1B4P	1.05	5D21	22.50	7E5/1201	.60	70L7	1.05	700D	17.95	876	.40
1B21A/GL471A	2.55	5FP7	1.75	7E6	.55	CEQ72	1.45	701A	3.00	878	1.75
1B22	3.40	5GP1	2.95	7F7	.60	CRP72	.95	702A	2.60	879/2X2	.45
1B23	7.50	5H-4 BALLAST	.45	7H7	.60	CYN72	1.65	703A/368AS	3.60	902	3.75
1B27	7.75	5HP4	4.75	7L7	.65	RKR72	.90	704A	1.05	931A	3.95
1B32/532A	1.85	5J23	13.00	7Y4	.50	RKR73	1.23	705A/8021	1.00	954	.30
1B42	6.75	5J29	13.45	9-3 BALLAST	.45	76	.40	706AY	17.50	955	.45
1B48	9.90	5U4G	.75	10	.50	77	.45	707A	12.95	957	.35
EL-1C	4.85	5W4	.76	10 ACORN	.55	78	.45	707B	14.45	958A	.35
1C5GT	.65	6-4 BALLAST	.35	10/VT25A	.53	VR78	.65	708A	3.45	967/FG17	3.75
1C6	.75	6-7 BALLAST	.35	10E/146	1.00	80	.45	709A	4.75	991/NE16	.24
1C7G	.85	6A3	.80	10T1 BALLAST	.50	FG81A	3.95	710A/8011	1.25	1005	.30
1D8GT	.90	6A6	.65	10Y/VT25	.45	83V	.90	713A	1.45	1007	4.50
1E7GT	.95	6AB7/1853	.95	12A6	.25	89	.42	714AY	3.55	CK1089	3.90
1G6	.65	6AC7/1852	.90	12A6GT	.25	89Y	.40	715B	6.55	CK1090	2.65
1L4	.50	6AF6G	1.10	12AH7GT	1.10	VR90	.95	717A	.60	1148	.35
1LC6	.75	6AG5	1.20	12BD6	.65	VT90 BRITISH	2.55	721A	2.60	1201	.45
1LN5	.80	6AH6	1.00	12C8	.40	VR92	.40	722A/287A	9.50	1203	.45
1P24	1.75	6AK5	1.20	12F5GT	.55	FG95/DG1295	9.95	723AB	14.95	1203A	.65
1Q5GT	.85	6AK6	.80	12H6	.35	VT98/RELS	14.95	724A	3.85	1236	1.75
1R4	.55	6AL5	.85	12J5GT	.35	100R	1.05	724B	3.85	1294/1R4	.55
1S5	.60	6AQ6	.65	12J7GT	.59	101/837	1.65	725A	6.85	DG1295	9.95
1T4	.65	6AU6	.65	12K8	.59	102F	3.55	726A	4.95	1299/3D6	.45
2A7	.70	6AV6	.65	12SA7GT	.62	FG105	9.75	726B	13.50	1299A	.60
2B7	.70	6B4G	.90	12SF7	.50	VU111S	.45	730A	9.95	1613	.55
2B22/GL559	1.75	6E7	.75	12SG7	.55	114B	.80	801	.40	1616	.75
2C22/7193	.35	6B8	.65	12SH7	.40	121A	2.55	801A	.65	1619	.35
2C26	.30	6B8G	.75	12SJ7	.60	122A	2.65	803	3.40	1624	1.25
2C26A	.40	6BA6	.65	12SK7	.55	VT127 BRITISH	.35	804	6.90	1625	.35
2C34	.40	6C4	.40	12SL7GT	.55	VT127A	2.95	805	5.75	1626	.35
2C40	5.25	5C5	.55	12SN7GT	.59	VR150	.48	808	1.65	1629	.35
2C44	1.25	5C6	.65	12SR7	.50	VT158	14.95	809	2.65	1630	2.75
2E22	1.10	6C8G	.70	12X825 2A.TUNG1	.45	FG172	19.25	811	2.35	1638	.65
2J21	10.45	6C21	19.10	13-4 BALLAST	.35	205B	1.35	812	2.95	1641/RK60	.65
2J21A	10.45	6D6	.50	14B6	.75	211/VT4C	.40	813	8.95	1642	.55
2J22	9.65	6F5	.65	14Q7	.55	215A/VT5	.28	814	2.60	1852/6AC7	.90
2J26	8.45	6F6	.60	15E	1.40	221A	1.75	815	2.35	1853/6AB7	.95
2J27	12.95	5F6G	.60	15R	.70	227A	2.90	826	.75	1960	.85
2J31	9.95	5F8G	.85	16X879 2A.TUNG1	.35	231D	1.20	830B	3.95	1961/532A	1.85
2J32	12.85	6G6G	.85	FG17/967	3.25	RX233A	1.95	832	6.50	1984	1.75
2J33	18.95	6H6	.45	19	.85	257A	3.00	832A	7.95	2051	.75
2J34	17.50	6H16 BALLAST	.45	20-4 BALLAST	.45	268A	2.95	834	5.75	UX6653	1.20
2J37	13.85	6J5	.45	REL-21	2.10	274B	2.65	835/38111A	1.00	7193	.35
2J38	9.95	6J5GT	.45	21-2 BALLAST	.45	282B	5.25	836	1.45	8011	2.55
2J48	19.95	6J6	.85	23D4 BALLAST	.45	287A/722A	9.50	837	2.25	8012	2.75
2J61	24.50	5J7	.65	RK24	1.55	304TH	3.70	838	3.10	8013	1.25
2K25/723A/B	14.95	6J8G	.95	24A	.40	304TL	1.95	841	.40	8020	2.10
2X2	.45	6K6GT	.55	VT25A/10	.45	307A/RK75	3.60	842	2.75	8025	6.75
2Y3G	1.20	6K7	.65	25Z5	.65	316A	.45	843	.40	9001	.45
3-16 BALLAST	.45	6K7G	.65	25Z6GT	.52	327A	2.50	851	39.00	9002	.40
3A4	.35	6L6	1.10	26	.55	350B	1.85	852	6.10	9003	.45
3A4/47	.45	6L7	.75	27	.55	354C	14.95	860	7.55	9004	.55
3B7/1291	.40	6N7	.85	28D7	.40	356B	4.95	864	.40	9006	.30
3B22	2.35	6N7GT	.85	30/VT67	.58	368AS/703A	3.75	865	1.85	38111A/835	1.00
3B24	1.75	6Q7	.55	30	.40	371A	.80				
3BP1	3.45	6R7	.75	33	.70	371B	.80				
EL-3C	3.95	6R7G	.75	34	.33	388A	2.95				
3C21	4.85	6R7GT	.55	RK34/2C34	.35	393A	3.60				
3C24/24G	4.45	6S7G	.85	35/51	.55	394A	3.60				
3C31/C1B	3.75	6SA7GT	.55	35W4	.45	395A	4.85				
3CP1/S1	1.95	6SC7GT	.65	35Y4	.50	MX408U BALLAST	.30				
3D6/1299	.30	6SF5GT	.65	36	.55	417A	14.25				
3D21A	.95	6SG7	.65	37	.35	434A	2.85				
3DP1	3.75	6SH7	.40	38	.35	446A	1.15				
3FP7	1.85	6SH7GT	.40	39/44	.30	446B	1.75				
3FP7A	2.28	6SK7GT	.50	43	.50	GL451	1.90				
3GP1	4.95	6SL7GT	.60	45SPEC. 7V. FIL.	.28	GL471A	2.75				
3H-1-7 BALLAST	.45	6SQ7	.55	46	.65	SS501	3.00				
3HP7	3.45	6SR7GT	.55	EF50	.45	527	12.85				
3Q5	.65	6U7G	.55	50B5	.65	WL530	2.75				
3QS5GT	.65	6V6GT	.75	50L6GT	.54	WL531	1.75				
3S4	.60	6X5GT	.75	VT52/45SPEC.	.28	WL532	1.65				
GA4	2.00	7-7-11 BALLAST	.35	56	.70	532A/1B32	1.85				
REL-5	14.95	7A4/XXL	.55	57	.45	GL559	2.10				
VT5/215A	.40	7A7	.56	58	.50	KU610	6.90				

PHOTO. TUBES.	
917/CE11V-C.	\$2.10
918/CE1C.	1.45
920/CE21D.	2.40
922/CE22C.	1.20
923/CE23C.	1.10
927/CE25.	1.25
930/CE30C.	1.20
SPECIAL TUBES.	
4B24/CE22A.	3.25
4B25/CE221.	7.85
4B26/CE226.	1.90
4B27/CE201A.	2.45
4B28/CE225.	2.40
4B35/CE212B.	7.65



Huge Display at Our LaSalle Street Show Rooms

320 N. LA SALLE ST. DEPT. E CHICAGO 10, ILL.

SPECIAL TERMINAL BOXES for V-5 and V-10 VARIACS*

VARIAC users have frequently asked for special terminal boxes for facilities impossible to fit in the space provided by the standard "T" terminal box regularly used with all V-5MT, V-5HMT, V-10MT and V-10HMT VARIACS.

We now stock a new, larger rectangular terminal box with sufficient room for almost any special terminal arrangement desired. Unlike the standard "T" box, the new box has a removable cover for easy access to its interior.

The boxes for the V-5 and V-10 series are identical and can be put on existing VARIACS by the customer with no difficulty. Both V-5 and V-10 VARIACS are now stocked with the new terminal cases.

Two boxes are available. The "TC" unit, a plain box with four BX or conduit knockouts and a blank cover, and the "TE" box equipped with a 3-wire outlet, cord and 3-terminal plug and a two-pole switch.



V-5MTE

VARIACS WITH SPECIAL WINDINGS

We receive many requests to modify the winding on VARIACS to furnish output voltages or voltage ranges different from the standard models, or to provide special input or output tap arrangements.

Where the quantities involved are sufficiently large to warrant special production, at a price reasonably low, we welcome your inquiries for VARIACS of this type.

When requesting quotations for these VARIACS please supply complete information to facilitate our prompt reply.

*Trade Name ®



V-10MTC

V-5MTC

SPECIFICATIONS

Dimensions of ALL Boxes: 2 7/8" wide, 3 3/4" high, 2" deep.

TYPE	DESCRIPTION	PRICE
V-5MTC	V-5 VARIAC with 4 knockouts in box...	\$24.00
V-5MTE	V-5 VARIAC with 3-wire outlet box, 3-wire cord and plug, 2-pole switch...	33.50
V-10MTC	V-10 VARIAC with 4 knockouts in box...	39.00
V-10MTE	V-10 VARIAC with 3-wire outlet box, 3-wire cord and plug, 2-pole switch...	48.50

BASIC BOXES

TC BOX	Plain box with 4 BX knockouts, blank cover	5 3.50
TE BOX	3-wire outlet, 3-wire cord and plug, 2-pole switch	13.50



GENERAL RADIO COMPANY Cambridge 39, Massachusetts

90 West St., New York 6 920 S. Michigan Ave., Chicago 5 1000 N. Seward St., Los Angeles 38

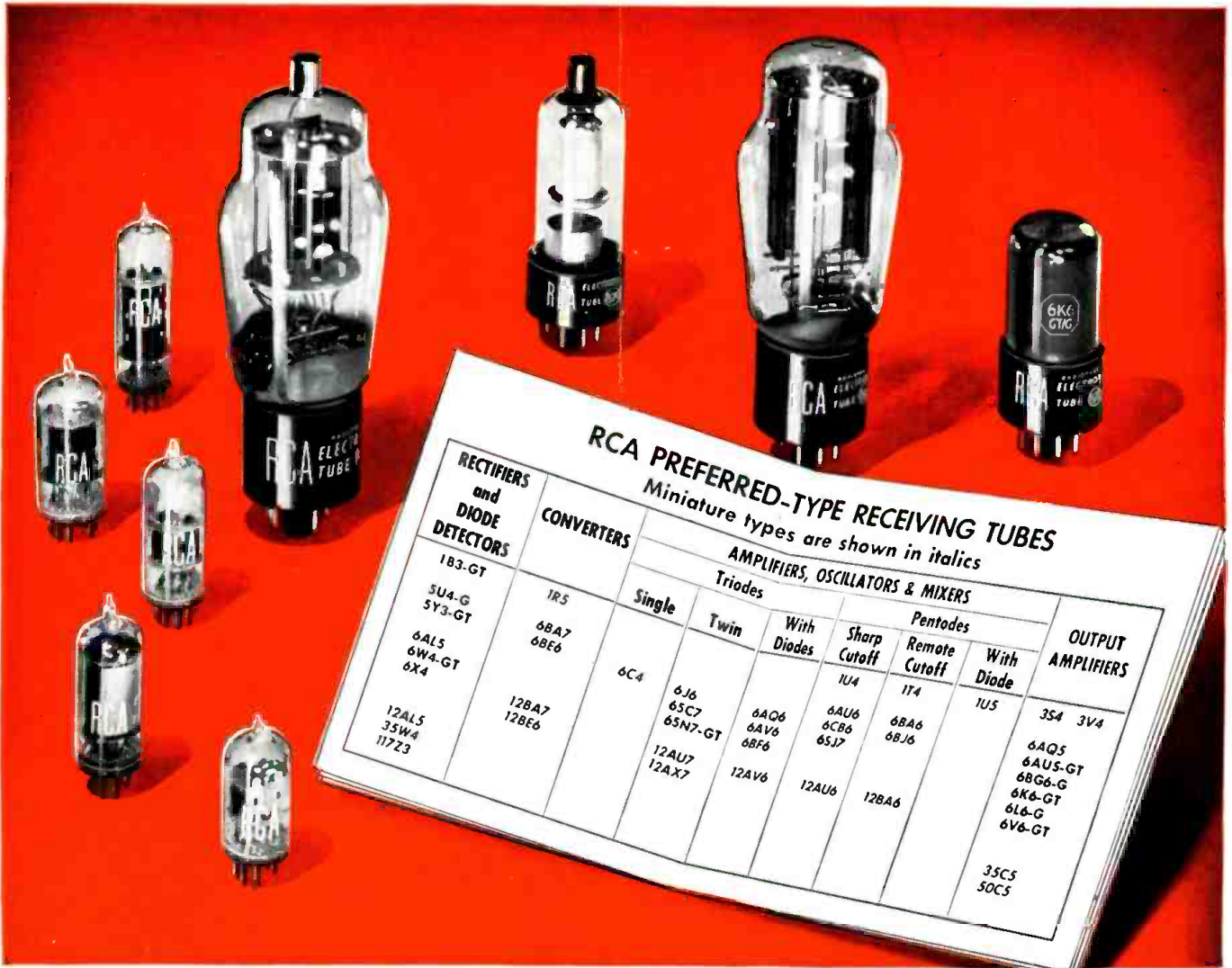

RCA PREFERRED-TYPE RECEIVING TUBES
Miniature types are shown in italics

RECTIFIERS and DIODE DETECTORS	CONVERTERS	AMPLIFIERS, OSCILLATORS & MIXERS						OUTPUT AMPLIFIERS	
		Triodes			Pentodes				
		Single	Twin	With Diodes	Sharp Cutoff	Remote Cutoff	With Diode		
1B3-GT	1R5								
5U4-G	6BA7								
5Y3-GT	6BE6								
6AL5	12BA7								
6W4-GT	12BE6	6C4	6J6	6AQ6	6AU6	68A6			3S4 3V4
6X4			65C7	6AV6	6CB6	68J6			6AQ5
			65N7-GT	6BF6	6S17				6AUS-GT
			12AU7	12AV6	12AU6	12BA6			68G6-G
			12AX7						6K6-GT
12AL5									6L6-G
35W4									6V6-GT
117Z3									35CS
									50CS

Balanced Program for design engineers

For TV, FM, and AM . . . RCA preferred-type receiving tubes offer these important advantages . . .

Flexibility—RCA preferred-type receiving tubes cover virtually every tube function essential in TV, AM, and FM receivers . . . and allow the engineer latitude to express individuality in his circuit designs.

Performance—These types have demonstrated their reliability over a period of time in circuits of widely different designs. Proved in service, they are most likely to succeed in future designs.

Economy—This group of 44 tube types represents more than half of RCA's current receiving tube volume. By concentrating production on these few types, substantial savings are realized in manufacturing costs which are passed on to the equipment manufacturer . . . and quality and uniformity are sustained at a high level.

Standardization—By concentrating on RCA preferred tube types, the equipment manufacturer also benefits

by his ability to standardize on component parts . . . resulting in purchasing and stocking economies.

A reference booklet (3F953), describing RCA's preferred-type receiving tubes and a wall chart (3F955R), listing these types, are available without charge.

Write RCA, Commercial Engineering, Section I58R, Harrison, New Jersey.



The Fountainhead of Modern Tube Development is RCA



RADIO CORPORATION of AMERICA

ELECTRON TUBES

HARRISON, N. J.